



Gas driven Pump Unit GPU

Product GPU-6

TA

13 Mar 2006

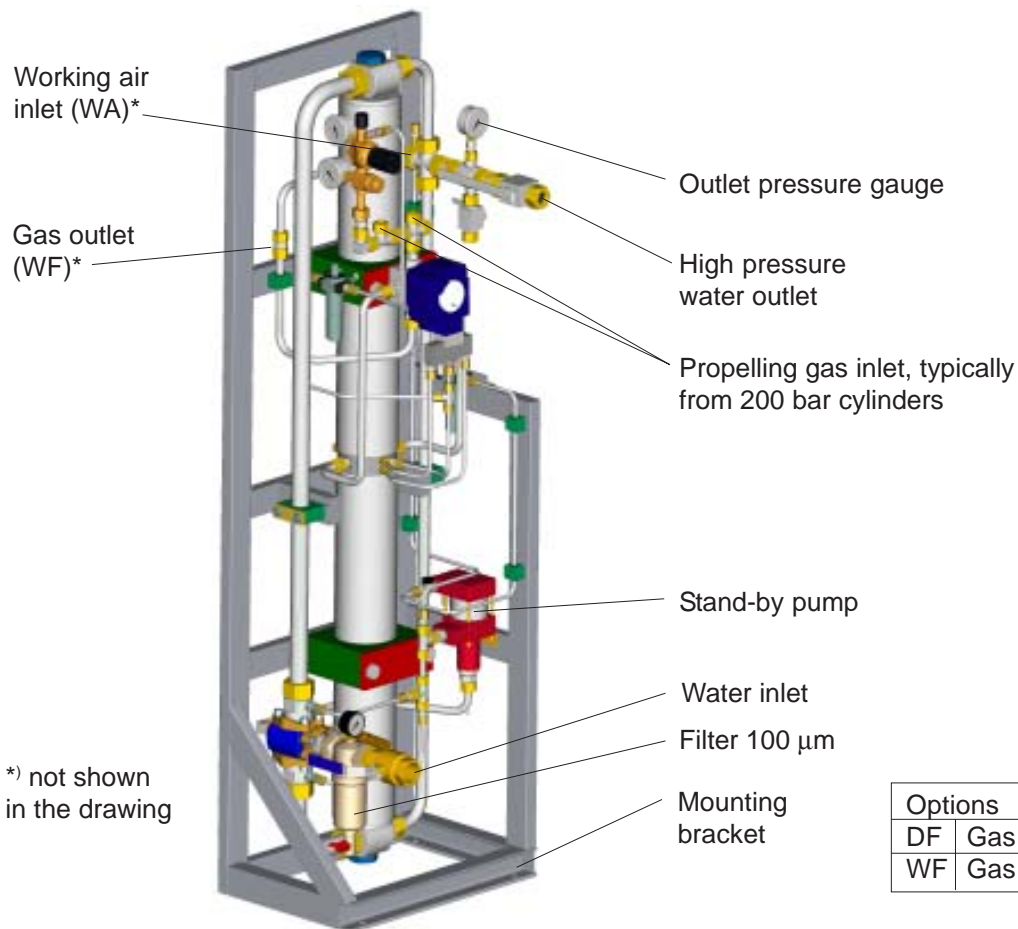

The GPU pump is propelled by pressurized air or nitrogen. The pump is a piston-type pump with two double-chambers. The gas is also used as an atomizing medium by feeding it into the system either directly (DF) or via water cylinder (WF). The feed water can be taken from a tank or from an external water supply. The pump starts when the propelling gas flows to the pump. A standby pressure of about 25 bar is maintained in the system by a pneumatic pump.

At each stroke, constant volumes of water and gas are discharged into the network. The operating pressure in the system is variable: in a macro scale the pressure at the sprinklers gradually decreases from (80 ± 10) bar down to zero, and in a micro scale there may be up to 20 bar peaks at regular intervals.

The water and gas supply of each system is dimensioned to provide the total suppressant required typically for that application. Max flow of the pump unit 120-150 l/min initially.

The discharge may be interrupted at any time by closing the shut-off valve.

The unit operation does not require any electrical power. Electrical power is applied for controlling, monitoring, and signaling of the system performance as described in the Client's contract specific requirements.

For further information, see related documents

Product	Model	Line Diagram no.	Part list
E61045	GPU-6-DF	DHDUGP000078B	THPUGP000078A
E61046	GPU-6-WF	DHDUGP000079B	THPUGP000079A





Gas driven Pump Unit GPU

Product GPU-6

TA

13 Mar 2006

Left side view

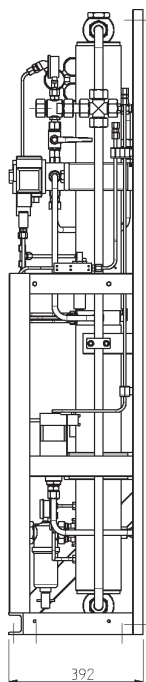

Front view

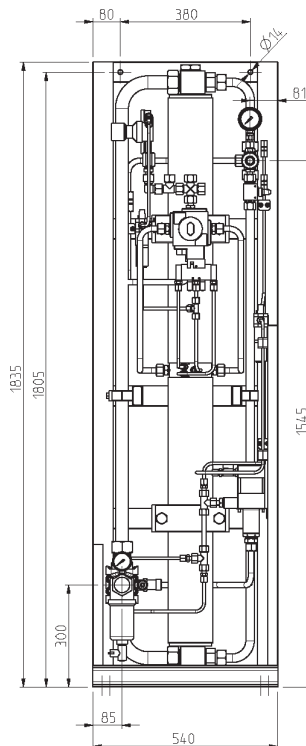

Right side view

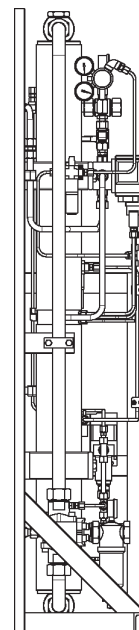

Top view

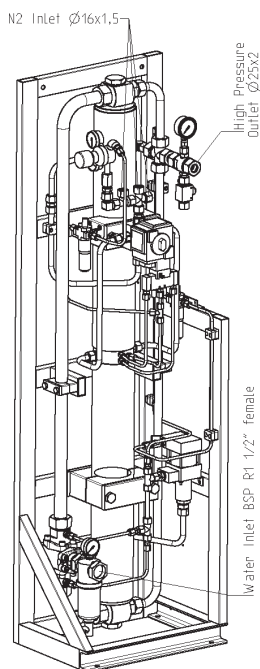
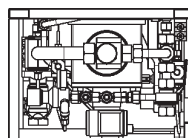

EXTERNAL PIPING CONNECTIONS

CONNECTION	TYPE / DIMENSION
N ₂ INLET	Ø16x1,5
WATER INLET	BSP R1 1/2" FEMALE
HIGH PRESSURE OUTLET	Ø25x2

