



HI-FOG®

# Integrated Gas driven Pump Units

WF -models (gas fed through water cylinders)

TA

23 Sep 2003

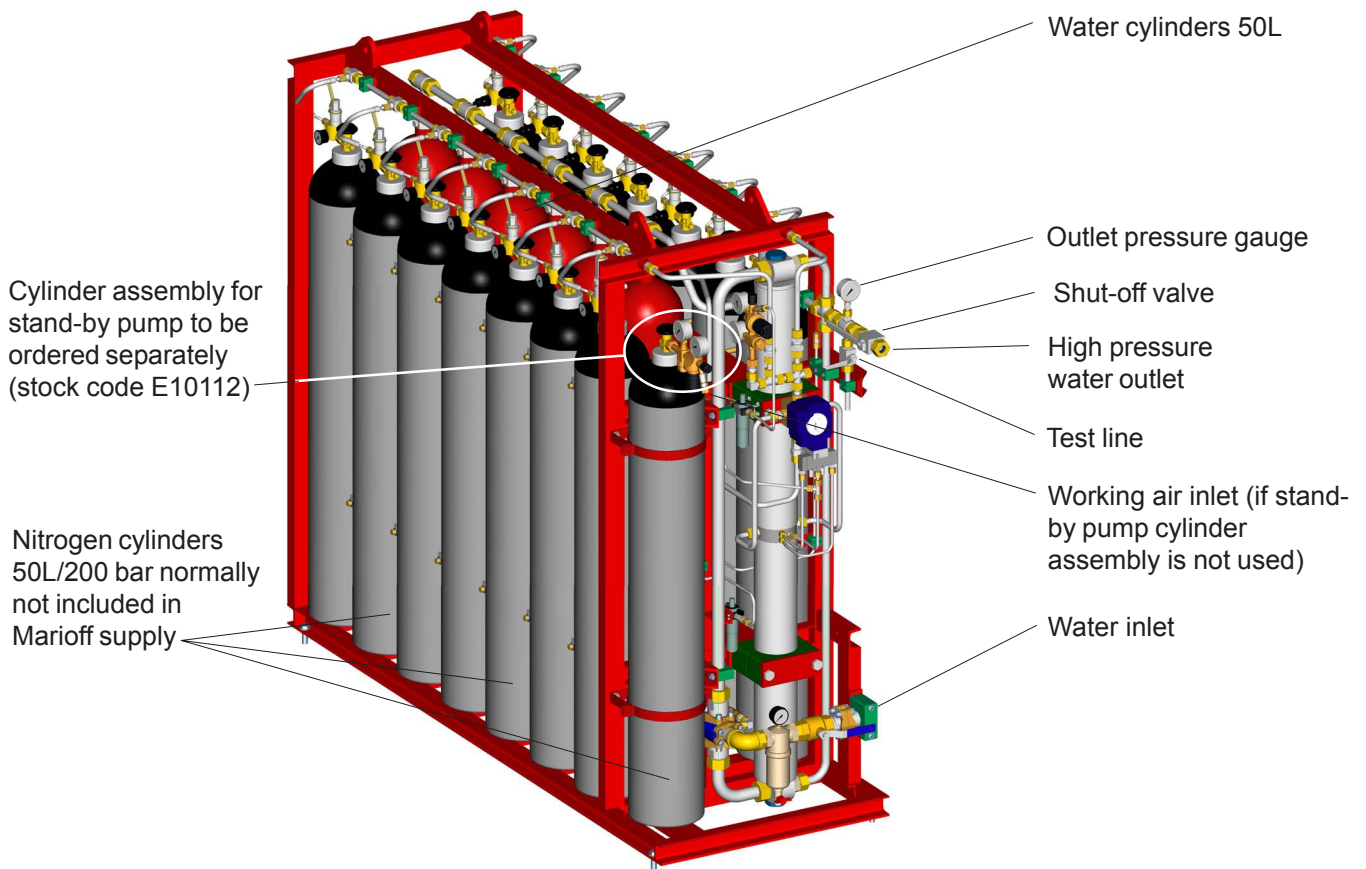

The GPU pump is propelled by pressurized air or nitrogen. The pump is a piston-type pump with two double-chambers. The gas is also used as an atomizing medium by feeding it into the system via water cylinder (WF). The feed water can be taken from a tank or from an external water supply. The pump starts when the propelling gas flows to the pump. A standby pressure of about 25 bar is maintained in the system by a pneumatic pump.

At each stroke, constant volumes of water and gas are discharged into the network. The operating pressure in the system is variable: in a macro scale the pressure at the sprinklers gradually decreases from  $(80 \pm 10)$  bar down to zero, and in a micro scale there may be up to 20 bar peaks at regular intervals.

The water and gas supply of each system is dimensioned to provide the total suppressant required typically for that application. Max flow of the pump unit 120-150 l/min initially.

The discharge may be interrupted at any time by closing the shut-off valve.

The unit operation does not require any electrical power. Electrical power is applied for controlling, monitoring, and signaling of the system performance as described in the Client's contract specific requirements.

Stock codes	Type codes**)	Line Diagram no.	Part list
E61014	GPU6 WF + 3+3 N 3W V*--	DHDUGP000256	THPUGP000256
E61019	GPU6 WF + 5+5 N 5W V*--		
E61033	GPU6 WF + 7+7 N 6W V*--		
E61028	GPU6 WF + 3+3 N 3W D*--	DHDUGP000256	THPUGP000256
E61029	GPU6 WF + 5+5 N 5W D*--		
E61034	GPU6 WF + 7+7 N 6W D*--		

\*\*\*) For complete type code, state the release and actuator valve types.

V\* = traditional valve  
D\* = burst disk valve





HI-FOG®

# Integrated Gas driven Pump Units

WF -models (gas fed through water cylinders)

TA

23 Sep 2003

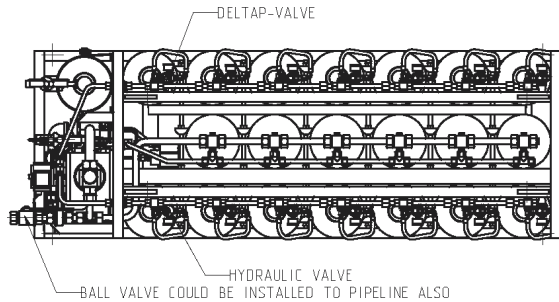
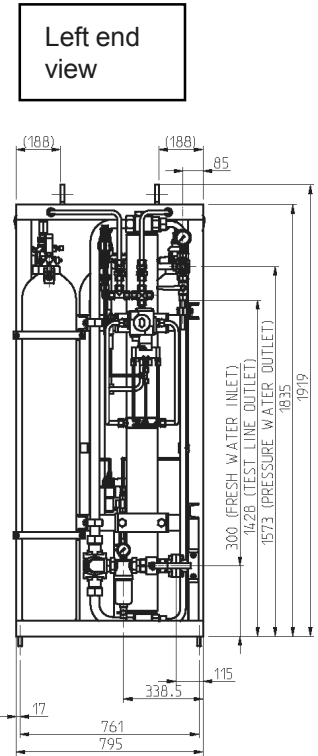
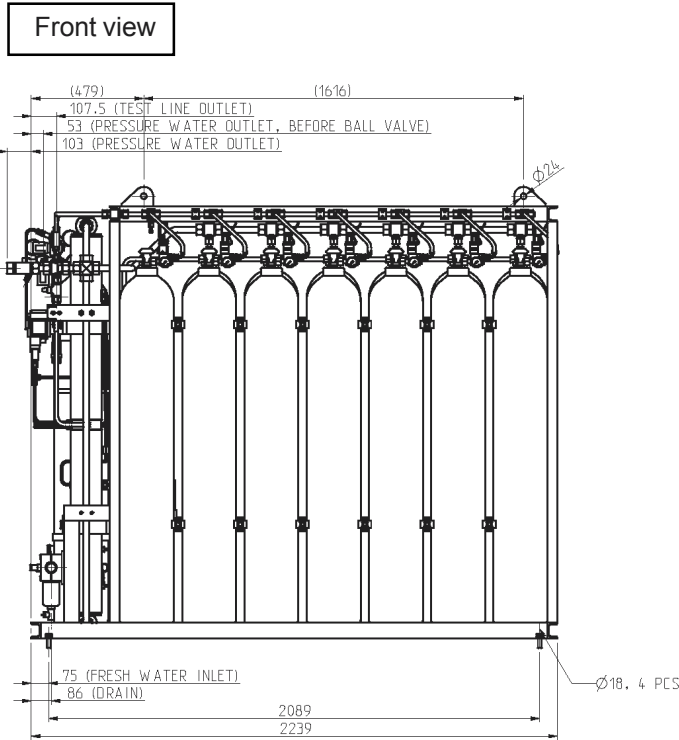

Top view

GPU6 WF + 7+7 N 6W shown with nitrogen cylinders and stand-by pump assembly set

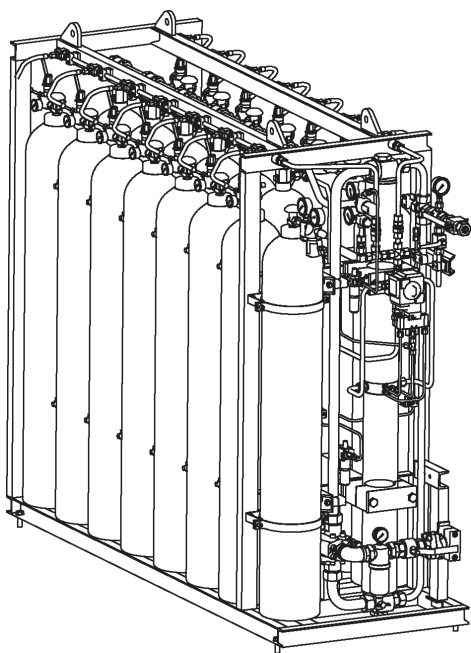

Main dimensions	Height [mm]	Length [mm]	Width [mm]	Mass, dry [kg]	Mass* [kg]
7+7+6W cylinders	1919	2239	795	~1600	~2070
5+5+5W cylinders	1919	2239	795	~1340	~1710
3+3+3W cylinders	1919	1450	795	~950	~1180

\* Water and gas cylinder filled but excluding stand-by assy and cylinder

Main dimensions	Height [mm]	Length [mm]	Width [mm]	Mass, dry [kg]	Mass** [kg]
Stand-by assy including cylinder	1646	~230	~230	~80	~90

\*\* Gas cylinder filled

External connections	
Pressure water outlet Test line outlet Fresh water inlet	Cutting ring 25-S acc. to DIN2353/ISO 8434-1 Cutting ring 16-S acc. to DIN2353/ISO 8434-1 SAE flange 1 1/2" 3000 PSI
Nominal cylinder diameter Max. cylinder height	230 mm ~1550 mm

