



HI-FOG®

Gas driven Pump Unit GPU6DF

Stock code E61025

21 Oct 2005

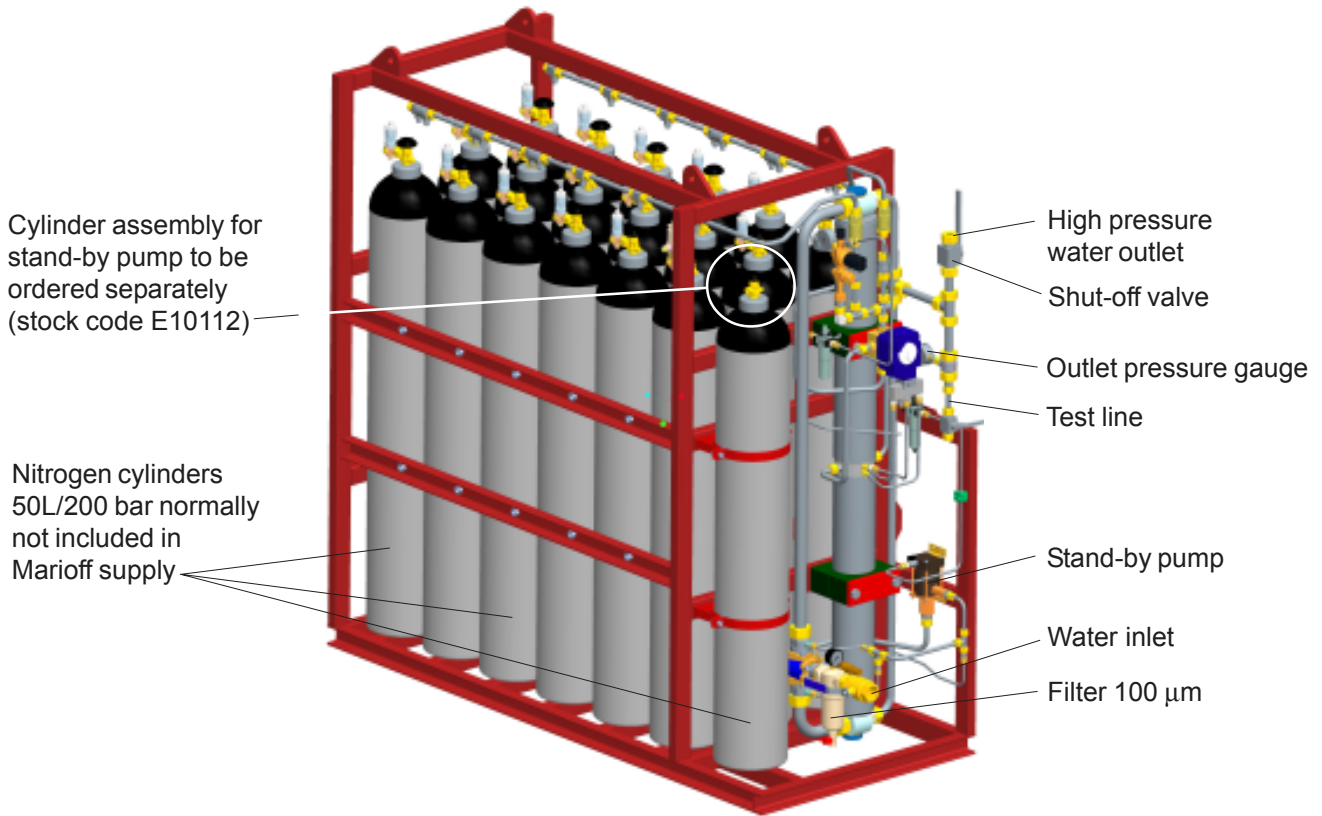

The GPU pump is propelled by pressurized air or nitrogen. The pump is a piston-type pump with two double-chambers. The gas is also used as an atomizing medium by feeding it into the system directly (DF). The feed water can be taken from a tank or from an external water supply. The pump starts when the propelling gas flows to the pump. A standby pressure of about 25 bar is maintained in the system by a pneumatic pump.

At each stroke, constant volumes of water and gas are discharged into the network. The operating pressure in the system is variable: in a macro scale the pressure at the sprinklers gradually decreases from (80 ± 10) bar down to zero, and in a micro scale there may be up to 20 bar peaks at regular intervals.

The water and gas supply of each system is dimensioned to provide the total suppressant required typically for that application. Max flow of the pump unit 120-150 l/min initially.

The discharge may be interrupted at any time by closing the shut-off valve.

The unit operation does not require any electrical power. Electrical power is applied for controlling, monitoring, and signaling of the system performance as described in the Client's contract specific requirements.

Stock code	Type code	Line Diagram no.	Part list
E61025	GPU6 DF (+9+9)N (+S) -D	DHDUGP001083	THPUGP001083





HI-FOG®

Gas driven Pump Unit GPU6DF

Stock code E61025

21 Oct 2005

Front view

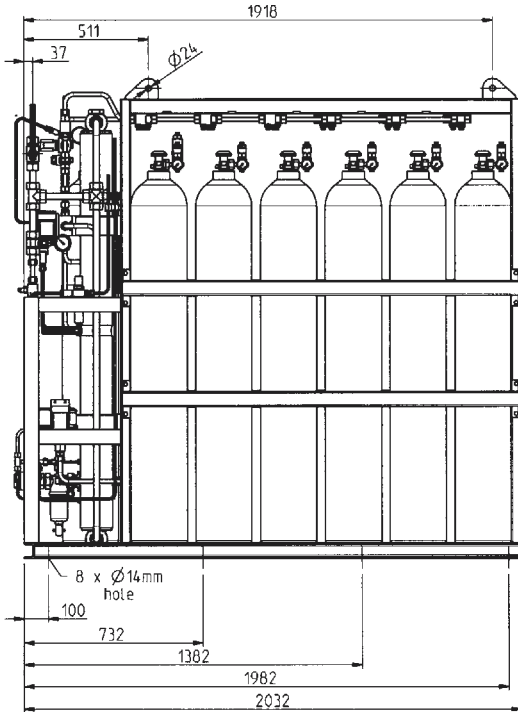

Left end view

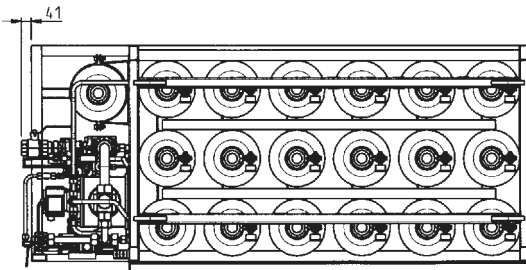
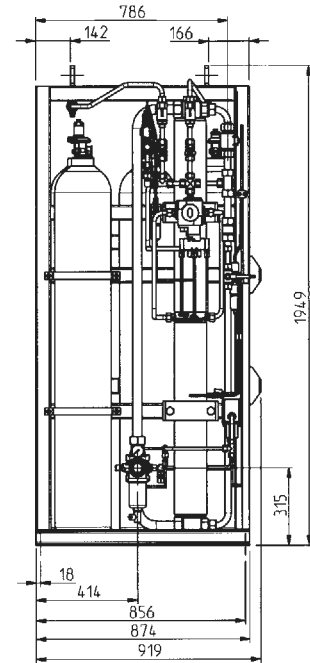

Top view

GPU6DF (E61025) shown with nitrogen cylinders and stand-by pump assembly set

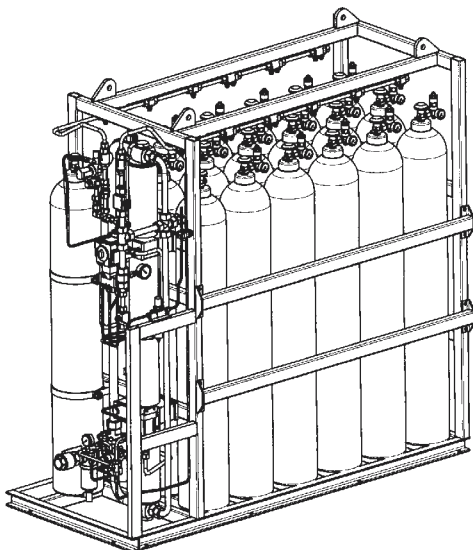

Main dimensions	Height [mm]	Length [mm]	Width [mm]	Mass, dry [kg]	Mass* [kg]
E61025	1949	2073	919	~	~

* Water and gas cylinder filled but excluding stand-by assy and cylinder

External connections	
Pressure water outlet	Cutting ring 25-S acc. to DIN2353/ISO 8434-1
Test line outlet	Cutting ring 16-S acc. to DIN2353/ISO 8434-1
Fresh water inlet	BSP 1 1/2" Female
Nominal cylinder diameter	230 mm
Max. cylinder height	~1550 mm

