

ABORT GATE

The Hansentek high speed Abort Gate is used prior to returning air from the dust collector back into the building. In the event of an explosion, the purpose of the Abort Gate is to redirect flames and pressure to the atmosphere, protecting personnel and the building.

The Abort Gate is controlled by an electrical signal generated by a spark detection system. The electrical signal releases the latching device, allowing the gate to open to the atmosphere. The gate is reset by a manual handle as per NFPA Code 664 (8-4).

Features of a Hansentek Abort Gate include:

- 110V A.C. power input
- Square or round inlet and outlet
- Reversible outlet cowl
- Bird screen on outlet cowl
- Rubber seal on door frame to create an air tight seal
- Can be used on positive or negative pressure ducting
- Heavy duty reinforced construction
- Custom sizes to suit – up to 72” sizes available
- Reversible reset handles



2316 So. 24th Street
Omaha, NE 68108
800.550.1AFP (1237) toll free
402.733.2800 voice
402.344.7469 fax
www.associatedfire.net
E-mail: info@associatedfire.net

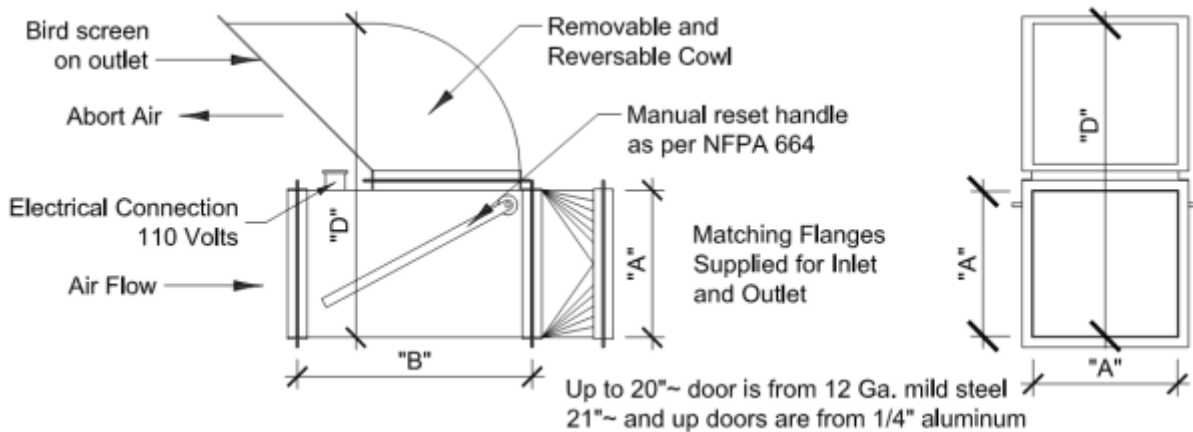

A – Size *	10	12	14	16	18	20	22	24	26	28	30	32	34
B – Overall Length **	20	23	26	29	32	34	37	40	43	46	48	51	54
C – Overall Width	18	20	22	24	26	28	30	34	36	38	40	44	54
D – Overall Height	23	27	31	35	39	43	47	52	56	60	64	70	74
Approx. Weight (lbs)	146	180	22	280	340	390	440	460	565	625	660	775	890

* Also available in odd increments

** Overall Length is body length only – add ~12” for transitions

HANSENTEK

