

Data/ Specification Sheet

AUTOPULSE® Z-10 AGENT RELEASE CONTROL PANEL

FEATURES

Agent Release Control Panel designed specifically for suppression release operation with:

- Four initiating device circuits (IDCs)
- Two notification appliance circuits (NACs)
- Two release appliance circuits (RACs)
- Two special purpose monitor inputs (SPMs) for manual release request and manual abort request
- Three auxiliary relays with selectable functions
- Easily selected activity timing options

Agent release operation includes:

- Automatic extinguishing release
- Deluge and preaction sprinkler system release
- Dual or single hazard area protection
- ▶ Combined agent release and preaction operation*
- IDCs are selectable for cross-zoning or for activation from a single detection input
- ▶ Short circuit RAC supervision

Operator interface provides:

- Status LEDs per circuit for Alarm, Trouble, and Supervisory (where appropriate)
- Acknowledge, alarm silence, and system reset
- Operating mode and timer selection when in programming mode

▶ **Audible Escalation of Events:**

- Single Audible Appliance Tone: Stage 1 activates Temporal or 20 bpm March Time pattern; Stage 2 activates 120 bpm March Time pattern to indicate release timer active; Release activates On Steady to indicate release timer expired and actuator is activated
- Dual Audible Appliance Control* (Single Hazard): RAC 2 provides a third NAC for dedicated Stage 1 Bell control; NACs 1 & 2 indicate release as On Steady

Compatible with Listed/Approved 24 VDC coil automatic water control valves

Required system components:

- Coil supervision module, Part No. 430687, one per solenoid control RAC
- Maintenance Switch, Part No. 433936 or 433937, one per solenoid control RAC

Recommended accessory (where appropriate):

- Abort Switch:
– Part No. 433940, Flush Mount

▶ * Requires software revision 4.01 or higher

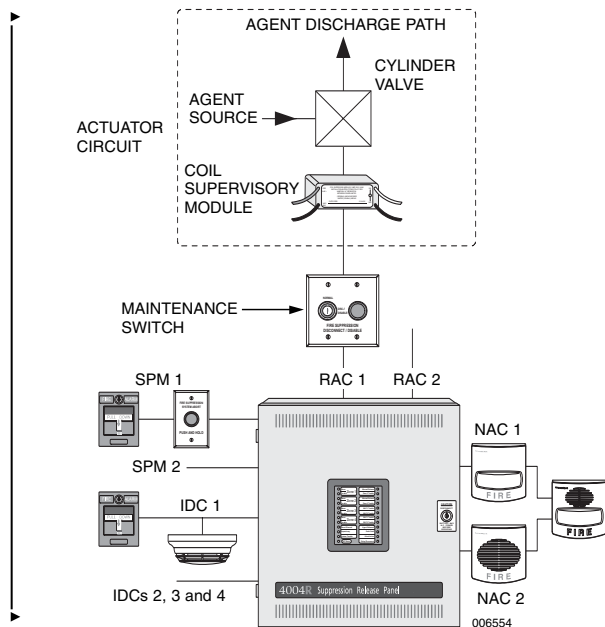

**AUTOPULSE Z-10 Agent Release Control Panel
One-Line System Reference Drawing**

INTRODUCTION

Dedicated for Agent Release: AUTOPULSE® Z-10 Suppression Release Panels provide conventional fire alarm control circuits and are equipped with the features required for a wide variety of single or dual hazard suppression release applications. Capabilities include automatic extinguishing agent release and deluge and preaction sprinkler control.

Flexible I/O Capabilities: Four IDCs allow for either four separately monitored zones or two, cross-zoned connections. Two SPMs allow dedicated manual inputs for release or abort. Two releasing appliance circuits (RACs) supervise to the actuator coils and activate the actuators when required. The two NACs and the three panel auxiliary relays provide status condition information.

Easy Program Selections: The operator panel has a program mode that allows selection of panel operation type and detailed operating selections using an easily selected sequential programming operation.

History Log: The last 50 events are stored in non-volatile memory. This information is accessed by connecting a technician's computer to the service port which is also used to set the date and time.

PANEL FEATURE DESCRIPTION

Operator Panel: The operator panel has alarm and trouble status indicating LEDs for each input and output, visible through the locking cabinet door. Unlocking the door provides access to the Acknowledge, Alarm Silence, and System Reset push-button switches.

Four Class B IDCs provide coverage for either two cross-zoned areas or four separately zoned areas. IDCs are capable of supporting up to 30 current-limited smoke detectors or electronic heat detectors as well as manual stations and other compatible contact closure initiating devices. IDCs are capable of Class A operation with an optional adapter module and can be programmed as Class C (short or open initiates a trouble) for use with current limited devices only.

- ▶ Single hazard agent release applications monitor low pressure switches on IDC3 and tamper switches with IDC4.



Tyco Safety Products
One Stanton Street
Marinette, WI 54143

PANEL FEATURE DESCRIPTION (Continued)

► **Two Class B Special Purpose Monitoring Circuits (SPMs)** are dedicated for manual release or abort, waterflow and supervisory, or release/abort and pressure, depending on system type. Inputs are normally open switches. An abort switch stops release while activated and upon deactivation, the release operation occurs after a selectable time delay. Manual release inputs override abort switches and activate the release after selectable delays of from 0 to 30 seconds in 5 second increments. For Dual Hazard applications, current limited abort operation is required. SPMs are programmable as Style C and capable of Class A operation with the optional adapter module.

Two Class B NACs are provided for reverse polarity, notification appliance operation, each rated 2 A. Class A operation is available with the optional adapter module. NAC operation is selectable per application.

Two Class B Release Appliance Circuits (RACs): Rated 2 A each, these circuits are dedicated to operating release control actuators. RAC cutout timing is selectable as no cutout, 45 seconds, or 1, 3, 3.5, 4, 5, 6, 7, 21, 25, 34, 44, or 64 minutes. For bell/horn/strobe single hazard applications, RAC 2 functions as a third NAC (NAC 3).

Auxiliary Power Output: Rated at 750 mA, this output can be wired as continuous or as resettable. Resettable is normally used to power 4-wire smoke detectors.

Standard Auxiliary Relay Outputs: Three relays outputs are available, selectable as normally open or normally closed, rated 2 A @ 30 VDC.

Trouble Relay (Aux Relay 1) is energized when Normal and is de-energized with a Trouble condition.

For Single Hazard Operation: Aux Relay 2 is the Alarm relay and Aux Relay 3 indicates Time Delay Started or can optionally be selected as a Supervisory relay.

For Dual Hazard Operation: Aux Relay 2 is for Hazard Area 1 Alarm; Aux Relay 3 is for Hazard Area 2 Alarm.

Power Supply and Battery Charger: During alarm, the power supply provides 3 A at 25.5 VDC, filtered and regulated. The temperature compensated battery charger provides 27.5 VDC for charging batteries suitable for up to 90 hour standby and 10 minutes of alarm. External battery chargers and cabinets can be used for more battery backup.

RELEASE CONTROL SYSTEM REFERENCE

Automatic Agent Release Systems: These systems automatically activate solenoid control valves for the release of a fire extinguishing agent in response to fire detection device input.

► **Automatic Extinguishing Release Systems with Separate Bell Control (single hazard)** (SW rev. 4.01 or higher). RAC 2 operates as a bell control NAC. When cross-zoned, stage 1 alarm activates the bell until the release timer starts. When not cross-zoned, stage 1 alarm activates the bell until expiration of the release timer. In both cross-zoned and non cross-zoned applications, NAC2 may be programmed to indicate either a tamper switch supervisory condition or the start of the release timer using a cadence pattern operation.

UL and FM Extinguishing Release System Panels must have a minimum of 24 hours of standby power. Initiating devices must be Listed/Approved for the application, and may be wired either Class A or B. Actuators must be electrically compatible with the control panel circuits and power supplies, and are wired Class B to provide coil supervision.

Deluge and Preaction Sprinkler Systems automatically activate water control valves in response to fire detection device input.

Deluge Sprinkler Systems employ open sprinkler heads and provide water flow when the fire detection system activates a common automatic water control valve. They are used to deliver water simultaneously through all of the open sprinkler heads.

AUTOPULSE Z-10 PRODUCT SELECTION

RELEASE CONTROL PANEL			
Part No.	Description	Reference	
430525	Basic Releasing Panel, operates with AC input of: 120/220/230/240 VAC, 50/60 Hz (auto-select)	Includes: Four IDCs, two NACs, two SPMs, two RACs, 3 A power supply with battery charger, cabinet and door	
EXPANSION MODULES			
Part No.	Description	Reference	
430529	Auxiliary Relay Module; four relays, Form C, rated 7 A @ 120 VAC, 5 A @ 30 VDC, unsupervised contacts	Two maximum	Select as required
430531	Two Circuit Class A Adapter Module for IDCs, SPMs, or NACs	Four maximum	
Batteries			
Part No.	Description	Reference	
417692	7.0 AH Battery Pack, 24 VDC	Select one battery shipping assembly per system standby requirements; two batteries are included	
417693	12 AH Battery Pack, 24 VDC		
417694	17 AH Battery Pack, 24 VDC	Requires external battery cabinet	
417695	25 AH Battery Pack, 24 VDC		
Release Control System Modules			
Part No.	Description		
430687	Coil Supervision Module, one required per RAC; refer to pages 6 and 7 for detail		
433936 or 433937	Maintenance Switch, one required per RAC		
433940	Abort Switch		
431196	Abort Supervision Module		

► This type of system is applicable where the immediate application of large quantities of water over large areas is the proper fire response.

Preaction Sprinkler Systems are similar to deluge systems except that normally closed sprinkler heads are used and supervisory air pressure is maintained in the pipe. Operation requires both an activated sprinkler head and an activated fire alarm initiating device.

Combined Agent Release and Preaction Systems provides agent release and preaction control. (Available with software revision 4.01 or higher.) For applications where agent release may not be sufficient for fire control, sprinklers are put in preaction mode to allow waterflow to continue the fire response. (Preaction is assumed, selected deluge could be provided, determined by the sprinkler installation, panel operation is the same.)

UL requirements for Fire Alarm Systems Listed for Automatic Release or Deluge and Preaction Sprinkler Systems are the same as described above for Automatic Extinguishing Release Systems.

FM Approved requirements for Fire Alarm Systems for Automatic Release of Deluge and Preaction Sprinkler Systems require operation of specific compatible FM Approved Automatic Water Control Valves, a minimum secondary power capacity of 90 hours, and all circuits for the automatic release initiating devices must be capable of operation during a single open circuit fault condition (Class A).

RELEASE CONTROL SYSTEM REQUIREMENTS

1. Solenoid valves are connected as 2-wire, Class B notification/releasing circuits with only one 24 VDC solenoid valve per circuit (or two, 12 VDC solenoids in series if applicable) to ensure supervision.
2. Coil Supervision Module, Part No. 430687, must be wired electrically before the solenoid valve and located in the solenoid valve wiring junction box.
3. For FM Approved Deluge and Preaction Sprinkler operation, initiating device circuits must be Class A, wired to Listed/Approved devices.
4. Power supply loading and wiring distances must be per Installation, Programming, and Operating Instructions, Part No. 430545.
5. For FM Approved Deluge and Preaction Sprinkler Systems, battery standby capacity must be a minimum of 90 hours with 10 minutes of alarm.
6. For FM Approved Automatic Extinguishing Release, battery standby must be a minimum of 24 hours with 5 minutes of alarm.
7. Battery standby must be selected for a minimum voltage of 23 VDC to ensure proper valve operation.
8. Maintenance Switch, Part No. 433936 or 433937, are required to allow the system to be tested or serviced.
9. For FM Approved Deluge and Preaction Sprinkler operation, the specified compatible Automatic Water Control Valves must be used.
10. For UL Listed and FM Approved Automatic Extinguishing Release, solenoid valves must be electrically compatible.
- ▶ 11. Abort Switch, Part No. 433940, is available when abort operation is required. When used, wire on Special Purpose Monitoring Circuits (SPMs) as Class A or B, the same as required for other initiating devices.
12. Manual Release Stations are used for direct activation of the release solenoids with the appropriate time delay implemented by the fire alarm control panel.

LISTINGS AND APPROVALS

- UL Listed: S4935
- FM Approved: J.I.3012391
- CSFM: 7165-0595:113
- MEA (NYC): 49-03-E

EXPANSION MODULES AND ACCESSORIES

Auxiliary Relay Module, Part No. 430529. Four relays per module are available as required. Dual hazard applications will require two modules for auxiliary relay operation. Each relay module has a manual disconnect switch that controls relays 2 through 4 (Trouble Relay is not controlled). Relay outputs are required to be connected to 15 A maximum circuit breaker.

Operation is per the following actions:

Relay 1 activates on any trouble associated with its hazard

Relay 2 activates on any alarm associated with its hazard

Relay 3 activates for pressure switch as required per application or actuates with second zone for cross-zoned systems (hazard specific)

Relay 4 activates when the hazard specific RAC activates

Dual Circuit Class A Adapter Module, Part No. 430531. This module converts two Class B circuits to Class A operation. It consumes no additional current and is compatible with IDCs, SPMs, and NACs. Up to four modules may be mounted within the AUTOPULSE Z-10 cabinet.

▶ **Maintenance Switch.** Proper service of release appliance circuits requires the ability to securely disconnect the release circuit during installation and maintenance. Maintenance switches are controlled by keyswitch and initiate a supervisory condition when in disconnect/disable position. Models with lamp are on a double-gang plate and are powered from separate 24 VDC wiring. Mounting is on stainless steel plates and models are available as either surface or flush mount (see drawing below).

Maintenance switches, one per RAC, are required per NFPA 72, the National Fire Alarm Code, to allow the system to be tested or serviced without actuating the fire suppression systems. Their use may not be allowed in some jurisdictions; always confirm local requirements. When used, maintenance switches are required to ensure that operation initiates a supervisory condition.



006549

Maintenance Switch

▶ **Abort Switch.** For manual abort requests, these abort switches are available with or without a built-in 1.2 kΩ, 1 W resistor and are mounted on single-gang stainless steel plates. Abort switches are connected to the SPM inputs per system requirements.

Activity abort occurs while the switch is pushed and continues after releasing the switch for the selected Abort Release Time Delay (see drawing below).

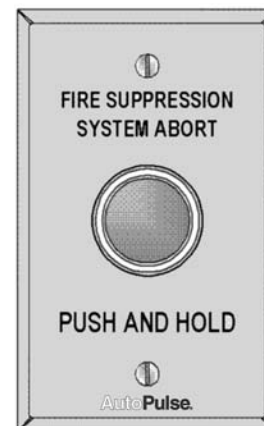

006550

Abort Switch

OPERATOR PANEL FUNCTION REFERENCE

LABEL INSERT SELECTABLE FOR PREACTION/DELUGE, AGENT RELEASE, OR COMBINATION AGENT RELEASE/PREACTION DELUGE, UL OR ULC VERSIONS (UL AGENT RELEASE VERSION SHOWN FOR REFERENCE)

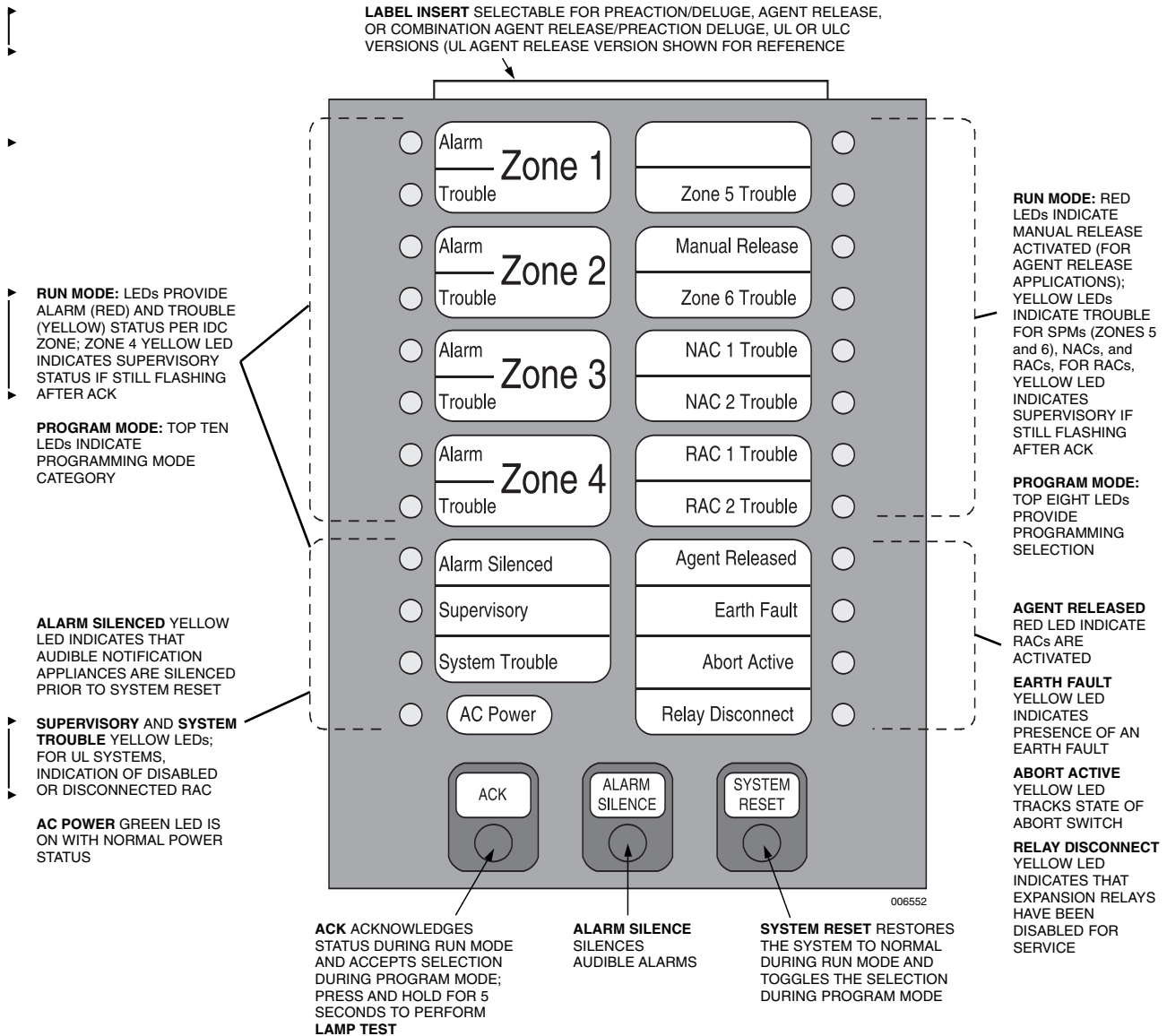

FM APPROVED WATER CONTROL VALVES

FM Group	Manufacturer	Model Number	Details
A	Skinner	LV2L BX25	24 VDC, 11 W, 458 mA, 1/2 in NPS, 1/2 in orifice
B	ASCO	T8210A107	24 VDC, 16.8 W, 700 mA, 1/2 in NPS, 5/8 in orifice
		R8210A107	
		8210A107	
C	Star Sprinkler	5550	24 VDC, part of Model D deluge valve
D	ASCO	8210G207	24 VDC, 10.6 W, 440 mA, 1/2 in NPS, 1/2 in orifice
		V2648571, N.C.	
		HV2648581, N.O.	
E	Skinner	73218BN4UNLVNOC111C2	24 VDC, 10 W, 420 mA, 1/2 in NPS, 5/8 in orifice
		73212BN4TN00N0C111C2	24 VDC, 10 W, 420 mA, 1/2 in NPS, 5/8 in orifice; 5-300 psi rated working pressure
F	Skinner	73212BN4TNLVNOC322C2	24 VDC, 22 W, 1/2 in NPS, 920 mA, 250 psi (1725 kPa), 1/2 in orifice
G	Skinner	71395SN2ENJ1NOH111C2	24 VDC, 10 W, 420 mA, 1/4 in NPS, 1/16 in orifice, 250 psi (1725 kPa) rated working pressure
H	Viking	HV-274-060-001	24 VDC, 22.6 W, 940 mA, 1/2 in NPS, 250 PSI (1725 kPa), 3/4 in orifice

SPECIFICATIONS

Power Ratings		
AC Input	Voltage Ratings	120 VAC, 60 Hz; 220/230/240 VAC, 50/60 Hz, auto-select
	Current Ratings	2 A maximum @ 120 VAC input; 1 A maximum @ 240 VAC input
Power Supply Output		3 A maximum available for external loads
Battery Charger		Temperature compensated, capable of recharging batteries required for 90 hour standby and 10 minute alarm (contingent on auxiliary power load)
Standby Current		100 mA; with IDCs fully loaded, tone-alert silenced, trouble LED on, charger off
Alarm Current		264 mA + external loads; (2 zones in alarm & 2 internal relays, NACs and RACs on)
Standard Circuit Ratings		(NOTE: Total DC current = 3 A maximum; see NAC ratings for details)
Initiating Device Circuits (IDCs)	Supervisory	3 mA maximum; 3.3 kΩ end-of-line resistor per circuit
	Alarm Current	75 mA maximum
	Output Voltage	28 VDC maximum
	Capacity	Each IDC supports up to 30 detectors (smoke or electronic heat) and manual stations as required; wiring distance is limited to 50 Ω maximum
Special Purpose Monitoring Circuits (SPMs)	Application	For Manual Release, Abort Switches, or Supervisory functions only; not for detectors; wiring distance is limited to 50 Ω maximum
	For Dual Hazard Applications	Dual Hazard Application Abort Switches require a current limiting resistor of 1.2 kΩ, 1 W, or an external Abort Supervision Module per SPM
	Supervisory	6 mA; 3.3 kΩ end-of-line resistor per circuit
	Activated	75 mA maximum
	Output Voltage	28 VDC maximum
Notification Appliance Circuits (NACs)		Special Application appliance rating = 2 A maximum on a NAC NOTE: Special Application appliance rating = full 3 A power supply rating
	Alarm Current	Regulated 24 DC appliance power = 1.5 A maximum on a circuit NOTE: Regulated 24 DC strobe load = 1.35 A maximum total for power supply
	Output Voltage	Alarm = 26 VDC max.; supervisory = 29 VDC maximum; 10 kΩ end-of-line resistor
	Synchronized Strobe Operation	Requires NAC dedicated to strobe control with non-coded output; use an external Synch Module; up to 33 strobes can be synchronized per Z-10
Notification Appliance Reference	Regulated 24 DC Appliances	Power for other appliances listed to UL Standard 1971 or UL Standard 464; use associated external synchronization modules where required
	Output Current	2 A maximum per circuit
Release Appliance Circuits (RACs)	Output Voltage	Activated = 26 VDC maximum; non-alarm = 29 VDC maximum; 10 kΩ end-of-line resistor
Auxiliary Power Output; for Special Application loads only		Two outputs are available, continuous operation or resettable operation; combined output is 750 mA maximum; output voltage = 19.25 to 27 VDC
Auxiliary Relay Outputs (Trouble, Aux Relay 2, Aux Relay 3)		Contacts rated 2 A @ 30 VDC, 0.35 p.f., inductive, selectable as N.O. or N.C. by jumper
Wiring Connections for Above and AC Input		Terminals rated for 18 AWG to 12 AWG (0.82 mm ² to 3.31 mm ²)
Auxiliary Module Ratings		
Class A Adapter Module 430531		Two circuits per module, rated same as circuits; not applicable to RACs (no additional current required)
Auxiliary Relay Module 430529	Relay Type	Four relays with two outputs per relay; individually selectable as N.O. or N.C.
	AC Ratings	7 A @ 120 VAC, resistive
	DC Ratings	5 A @ 30 VDC, 0.35 power factor, inductive

SPECIFICATIONS (Continued)

Auxiliary Module Ratings (Continued)		
Auxiliary Relay Module	Module Current	12 mA standby; 70 mA with all four relays energized; @ 24 VDC
430529 (Continued)	Wiring	Terminals rated for 18 AWG to 12 AWG (0.82 mm ² to 3.31 mm ²)
Coil Supervision Module		
	Construction	Epoxy encapsulated
	Dimensions	1-3/8 in. W x 2-7/16 in. L x 1-1/16 in. H (34 mm x 62 mm x 27 mm)
	Wiring	18 AWG (0.82 mm ²) wire leads, color coded
	Coil Supervision Module Current Rating	2 A maximum; internally fused at 3 A, non-replaceable
Environmental Ratings		
	Operating Temperature Range	32 °F to 120 °F (0 °C to 49 °C)
	Operating Humidity	Range up to 93% RH, non-condensing @ 100.4 °F (38 °C) maximum

REFERENCE INFORMATION, COMPATIBLE DETECTORS

Part No.	Type	Component Sheet
430559	LIFEalarm® Photoelectric Detector 2.8%/ft Obscuration (Standard)	T-2007153
430562	LIFEalarm® Photoelectric Detector 3.5%/ft Obscuration	
430565	135° F (57°C) Fixed Heat Detector	T-2007159
430566	200° F (93°C) Fixed with Rate-of-Rise Heat Detector	T-2007159
	NOTE: For proper detector bases, refer to Component Sheet T-2007153.	

AUTOPULSE Z-10 SYSTEM CONNECTION REFERENCE

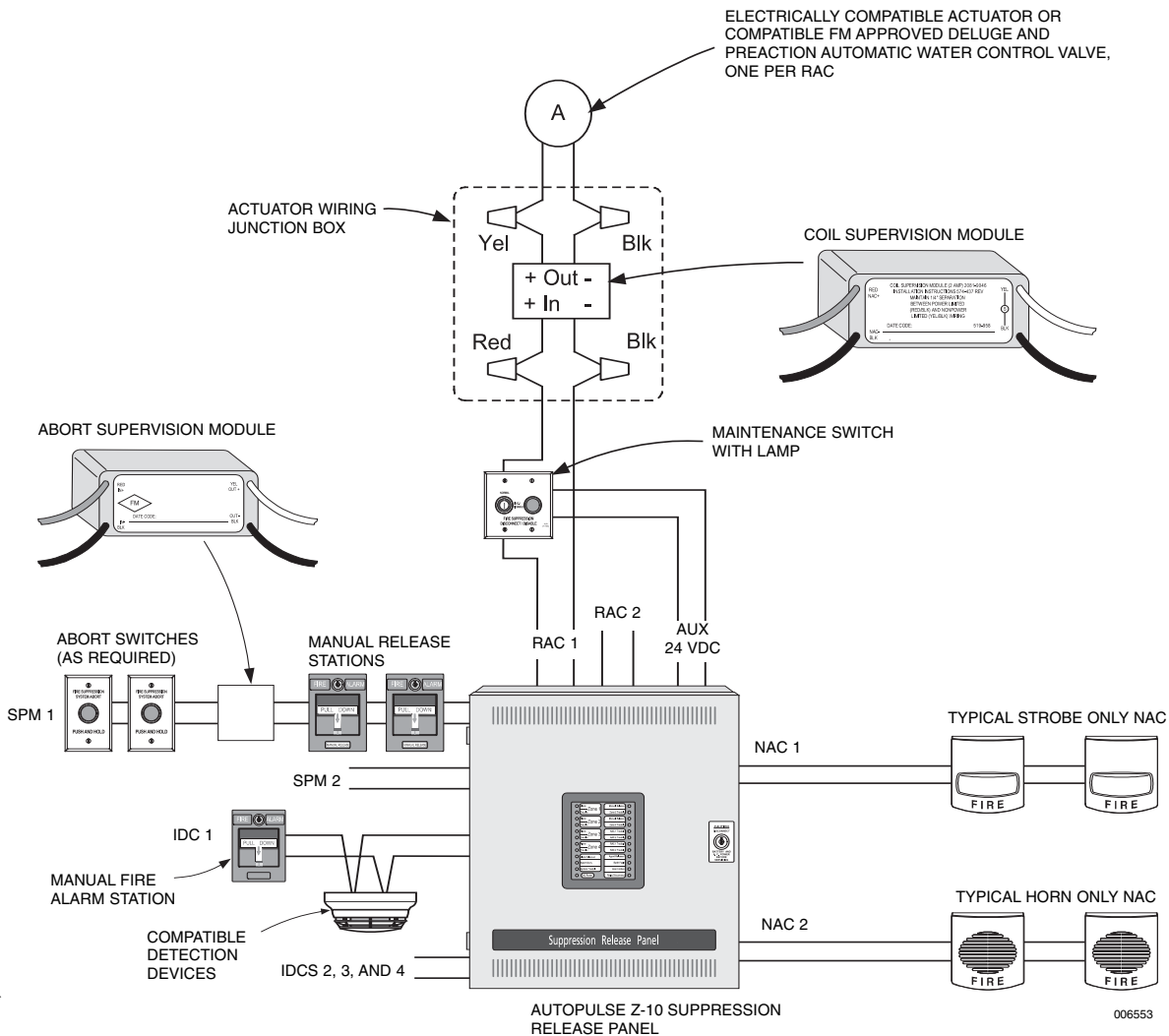

GENERAL WIRING NOTE:
 WIRING SHOWN IS FOR REFERENCE ONLY, REFER TO SPECIFIC
 INSTALLATION INSTRUCTIONS FOR DETAILED WIRING INFORMATION.

PROGRAMMING MODES AND SELECTION CHOICES

Sequence	Select one of 13 Application Modes (<i>numbered 1 through 13 in italics</i>)			
1	Agent Release	Single Hazard	Cross-Zoned 1 Either Zone 2	Combined Release (RACs activate together)
		Dual Hazard	Cross-Zoned 3 Either Zone 4	Independent Release (RACs are separate)
	Preaction/Deluge	Single Hazard	Cross-Zoned 5 Either Zone 6	Combined Release (RACs activate together)
		Dual Hazard	Cross-Zoned 7 Either Zone 8	Independent Release (RACs are separate)
	Agent Release; Single Hazard	Cross-Zoned 9	NYC Abort (not UL listed)	
	Agent Release & Preaction; Single Hazard	Cross-Zoned 10 Either Zone 11	RAC 2 provides Preaction Control; RAC 1 is Agent Release Control	
	Agent Release, Bell/Horn/Strobe; Single Hazard	Cross-Zoned 12 Either Zone 13	RAC 2 operates as NAC 3 for Stage 1 Bell Control (separate sound from release alarm)	
Sequence	Programming Mode Description	Description		
2	Select Relay Operation for Application Modes 1-9	Select "Original" operation mode or "Enhanced" mode		
3	IDC and SPM Circuit Style	Class B/Class A or Style C		
4	Automatic Release Time Delay	Selectable in 5 second increments from 0 to 60 seconds (default is 60 seconds)		
5	RAC Cutout Timer	No cutout, 45 seconds, or 1, 3, 3.5, 4, 5, 6, 7, 21, 25, 34, 44, or 64 minutes		
6	Manual Release Time Delay	0, 5, 10, 15, 20, 25, or 30 seconds		
7	Abort Release Time Delay	UL Standard 864 listed	Immediate or 10 seconds remaining	
		Not UL Standard 864 listed	IRI abort (cross-zoned systems only), NYC abort, or original release delay	
8	NAC Coding (where selectable)	Temporal pattern or 20 beats per minute (first cross-zone alarm)		
9	Standard Operation	No inhibit or one minute inhibit selected as: both on until silence, NAC 1 on until reset and NAC 2 on until silence, or both on until reset;		
	Pre-Discharge Operation	NOTE: For clean agent release, a pre-discharge NAC must be configured to warn of impending discharge, the release timer selects the duration of the pre-discharged signal		
10	Supervisory Latching	Latching or non-latching		
11	Supervisory Notification	LED and tone-alert only, or with: NAC 2 also on; Aux Relay 3 also on; or both NAC 2 and Aux Relay 3 also on		

MOUNTING REFERENCE INFORMATION

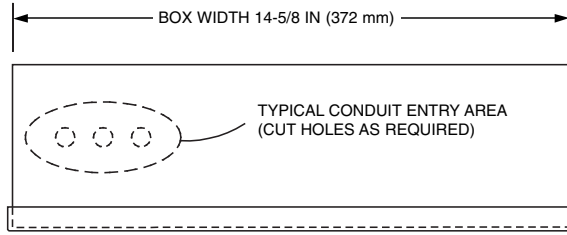

(TOP AND SIDE VIEWS ARE SHOWN WITH DOOR INSTALLED)

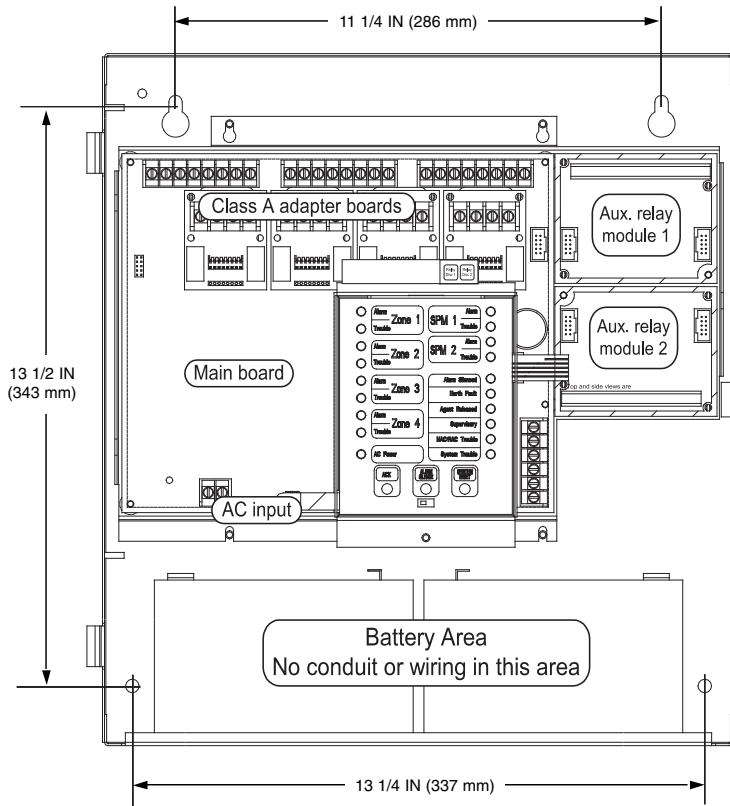

(FRONT VIEW MODULE PLACEMENT REFERENCE SHOWING MOUNTING HOLE DIMENSIONS, OPTIONAL CLASS A ADAPTER MODULES, AND OPTIONAL RELAY MODULES)

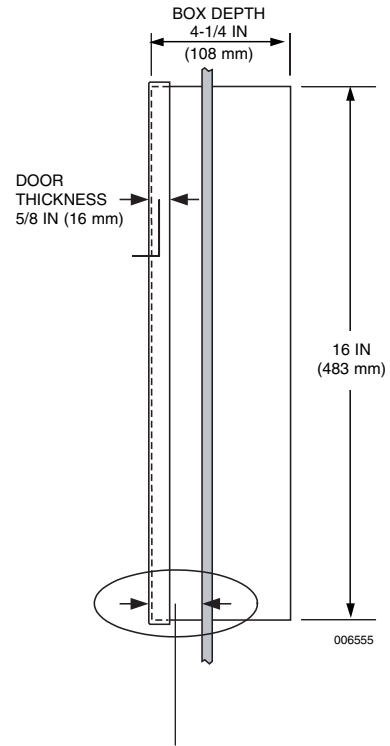

NOTE: FOR SEMI-FLUSH MOUNTING, CABINET MUST EXTEND 1-1/2 IN (38 mm) MINIMUM FROM WALL SURFACE

NOTE: A SYSTEM GROUND MUST BE PROVIDED FOR EARTH DETECTION AND TRANSIENT PROTECTION DEVICES. THIS CONNECTION SHALL BE MADE TO AN APPROVED, DEDICATED EARTH CONNECTION PER NFPA 70, ARTICLE 250, AND NFPA 780.