

Technical Data Sheet DOC0002076

Sprinkler Pump Unit SPU 2+1

Product E01221.4

08 Feb 2008

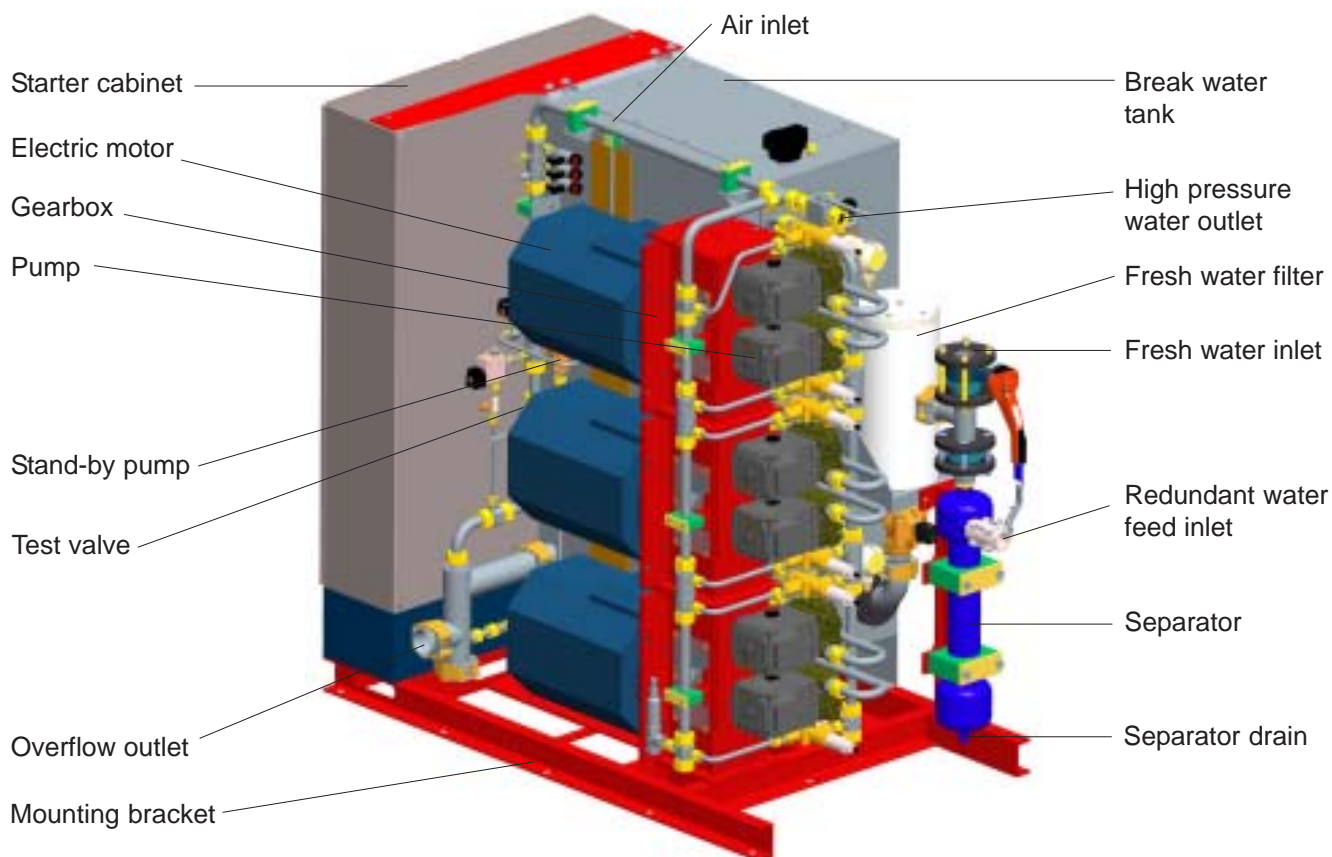

Unit output pressure	Length [mm]	Width [mm]	Height [mm]	Mass (dry) [kg]	Mass (wet) [kg]	Max. output [lpm]
140-80 bar	1835	1000	1777	1550		195
140-140 bar				1770		

Description

The SPU 2+1 consists of two pump modules, added with one more redundancy pump module required in Marine installations. Each module consists of an electric motor running via gearbox two high pressure pumps to produce the high pressure water flow needed in the sprinkler system in the case of a fire accident.

The pressure produced by pumps can be adjusted from 80 bar to 140 bar respectively, according to the application. The pump modules are started sequentially, thus reducing the electric power peak loads. In stand-by position, the system pressure is maintained at 25 bar by means of the pneumatic stand-by pump.

The pump unit can be started automatically or manually. Automatic start is activated by either the flow signal or the pressure signal. Manual start can be launched either from the external release panel or from the Starter Cabinet, switching on the pump modules one by one. External release and indication panel is normally included in the Marioff supply. The system start signal can also be given by the fire detection system (FDS) via the external panel.

NOTE! Service area requirement

Reserve free space around the unit: at least 500 mm on both sides of the motors and at least 700 mm in front of the starter cabinet doors. This area needs to be kept available for service and maintenance work.



Sprinkler Pump Unit SPU 2+1 Starter Cabinet

Starter Cabinet for product E01221.4

08 Feb 2008

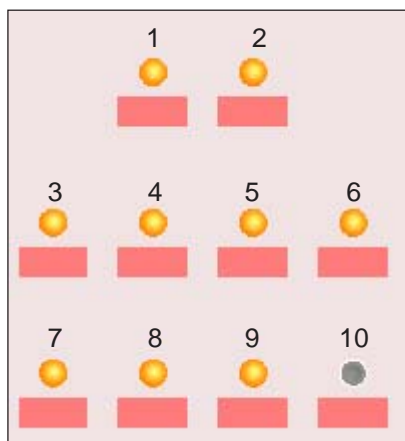

Manual start switch, lamp and motor ampere meter (x 3)

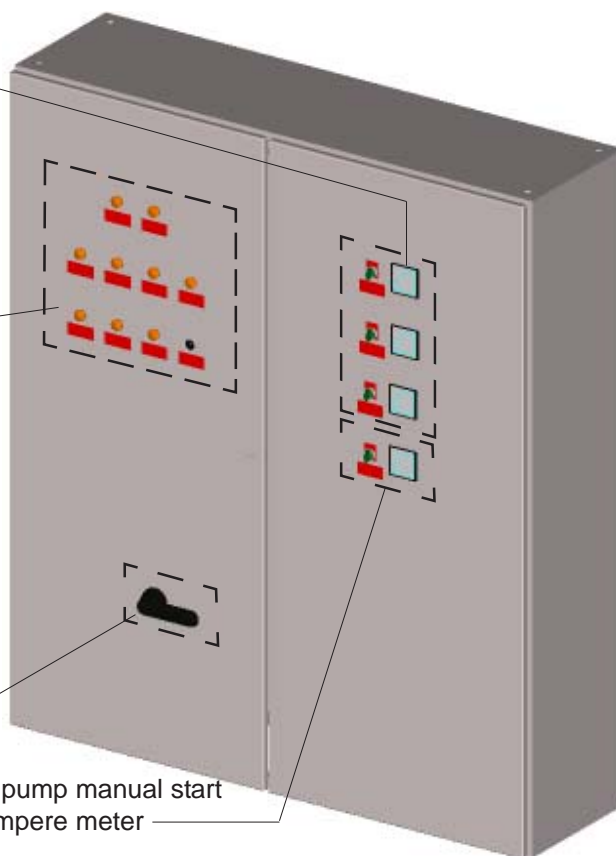

- 1. Main Switchboard Power supply indication lamp
- 2. Emergency Switchboard Power supply indication lamp
- 3. Control system on lamp
- 4. 24 VDC power supply failure
- 5. 24 VDC earth fault
- 6. Reset switch and lamp
- 7. Pump unit fault
- 8. Out of water
- 9. Nitrogen pressure low
- 10. Lamp test push button

Main power switch

Optional fresh water feed pump manual start switch, lamp and motor ampere meter

The electric power to the starter cabinet is normally supplied from the Main Switchboard (MSB). In case of a power failure, the supply from the Emergency Switchboard (ESB) is automatically switched on. Cable openings are at the bottom of the Starter Cabinet. The enclosure class is IP54.

The following signals will usually be led to the ship's automation system: HI-FOG system activated, pump unit fault, out of water in break water tank. In addition, the start request to the external feed water pump is given if the starter of the feed water pump is not in the starter cabinet.

The starter cabinet is equipped with necessary devices to master the optional Water Accumulator Unit control.

When ordering the SPU, the Starter Cabinet must be defined separately (various voltage, frequency and other options available). Other hardware options and possible FDS connections must also be defined when ordering the unit.

Options for	SPU 2+1 140-140/195 SEP xx, SPU 2+1 140-80/195 SEP xx (with redundancy pump module):
	Feed water pump starter in the Starter Cabinet. Soft starters for each high pressure pump motors to reduce the starting current of the motors. Stand-by heaters for the motors.

Voltage and Frequency options (to be defined when ordering)	
140-80 bar units, 2 x 15,5 kW, total 31,0 kW	
140-140 bar units, 2 x 27 kW, total 54,0 kW	
690 VAC 50 Hz	690 VAC 60 Hz
400 VAC 50 Hz	440 VAC 60 Hz
380 VAC 50 Hz	



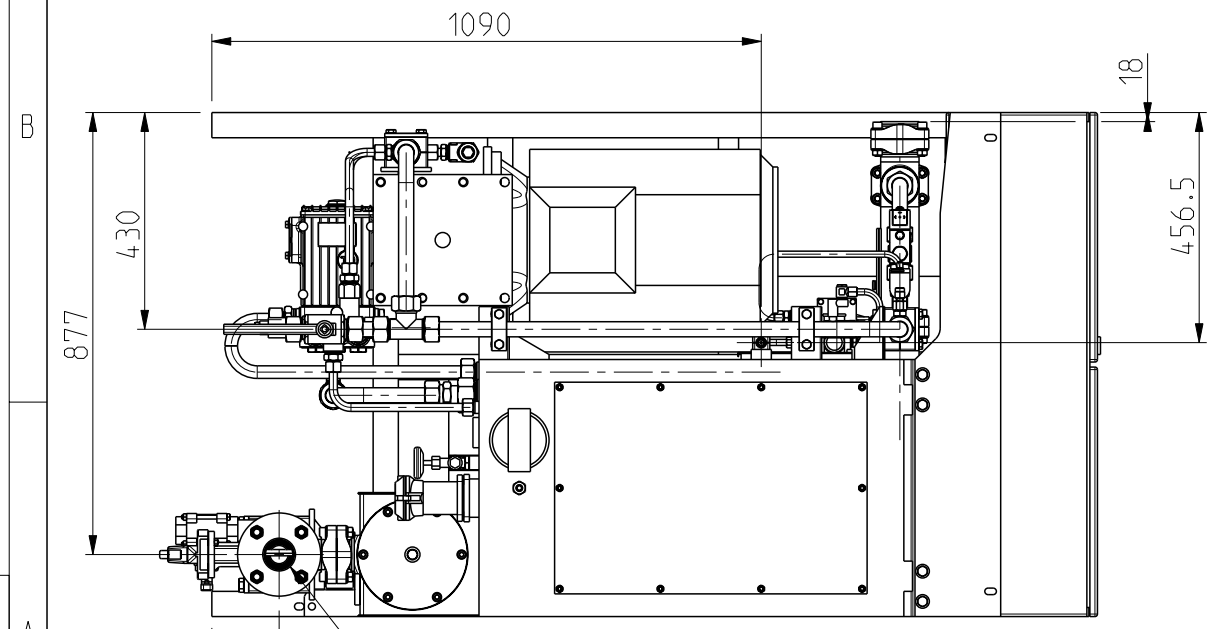
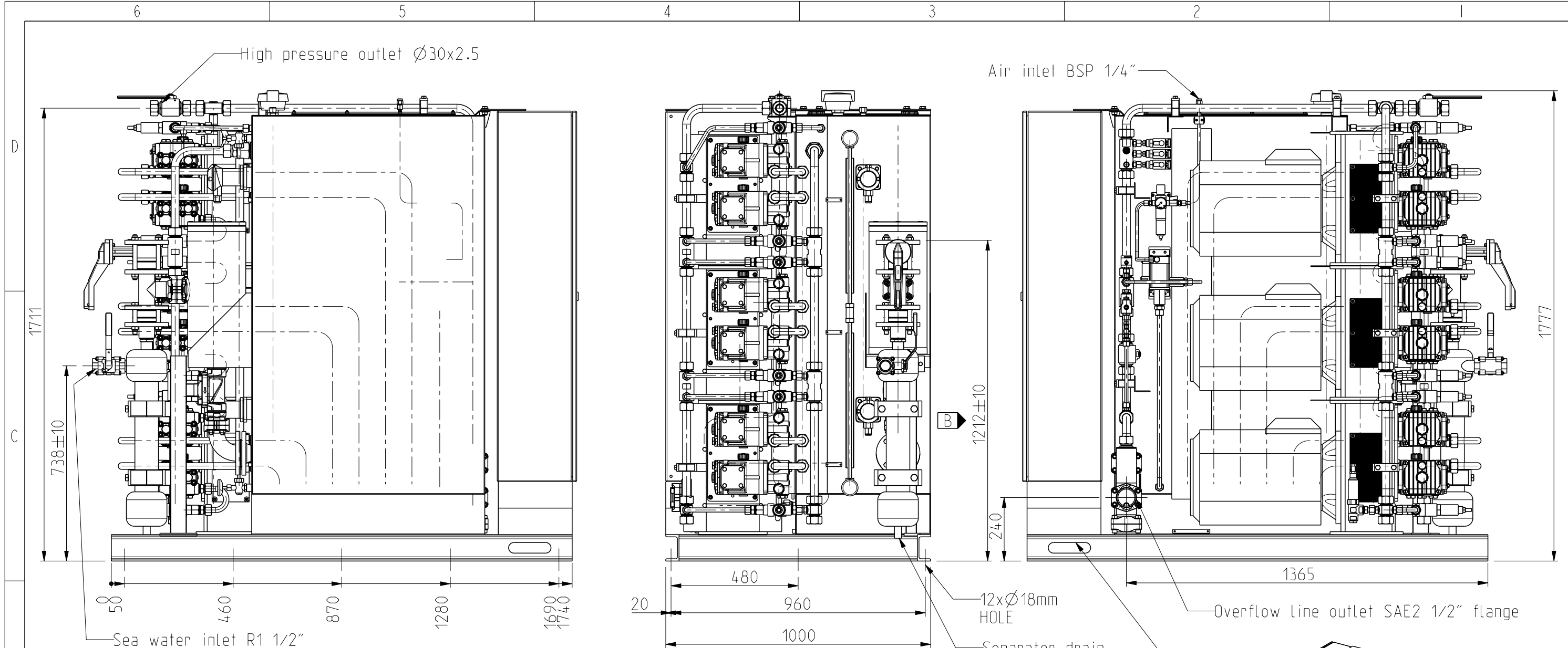

EXTERNAL PIPING CONNECTIONS	
CONNECTION	TYPE / DIMENSION
AIR INLET	BSP 1/4" FEMALE
FRESH WATER INLET	DN50 DIN2642 FLANGE
SEA WATER INLET	BSP R1 1/2" FEMALE
HIGH PRESSURE OUTLET	Ø30x2.5 DIN2353 CUTTING-RING FITTING
SEPARATOR DRAIN LINE	Ø12x1.2 DIN2353 CUTTING-RING FITTING
TANK OVERFLOW OUTLET	SAE 2 1/2" (Ø76.1x2) 3000PSI FLANGE

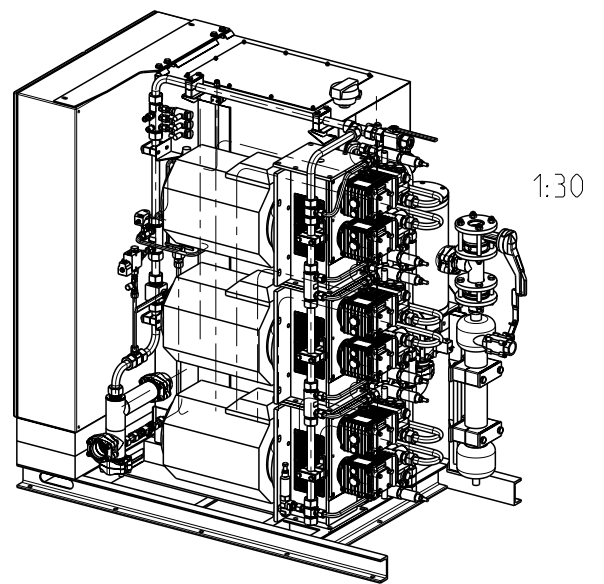

		Name Nimitys		PUMP UNIT		Mass Massa	0.000 kg
		Product Tuote		SPU 2+1 SEP (IL-0125)		Made Tekijä	JSA 090107
Scale Suhte	1:15	Drw. no. Piir. no	DMAUSP002391 E		Material Materiaali	Chkd Tark.	Appd Hyv.
Units Yksikkö	mm	Model	E01221_4_SPU2_1_SEP_IL-0125		General Tolerance	Release level	WIP
This drawing is a property of Marioff Corp. It is not to be disclosed, traced, copied or published without our written consent. Not to be misused in any way		Replaces				Sheet Sivu	1/1

Rev.	Reason of Reviewing	Date	Reviewed	ECO No.
E	Korjauksia kuvan tietoihin	28.01.08	JM	0001050
D	Lisätty R1/4" palloventtiili	27.08.07	PH	0000737
C	Lisätty painekeytkin ja -lähetin	20.08.07	PH	0000737

SPU2_1_SEP_IL-0125