

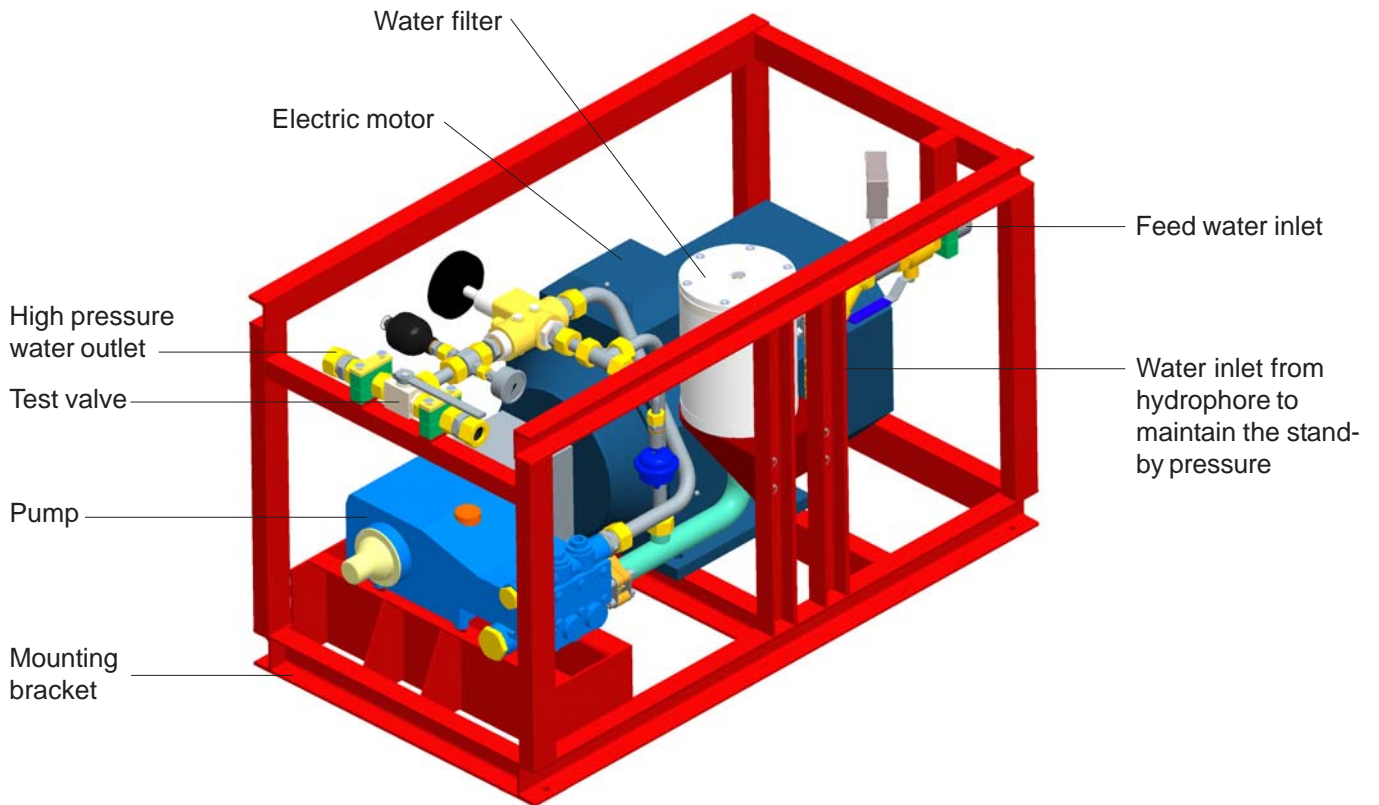

# Machinery Local protection Pump Unit MLPU1

Product E01210.3

15 Jan 2009



Stock code	Current freq. [Hz]	Power [kW]	Length [mm]	Width [mm]	Height [mm]	Mass (dry) [kg]	Pressure [bar]	Max. output [l/min]
E01210.3	50	23	1350	730	815	450	70	164
E01210.3	60	28	1350	730	815	450	70	195
E01210.3	50	30	1350	730	815	450	90	164
E01210.3	60	35	1350	730	815	450	90	195

### Description

The MLPU1 consists of an electric motor propelling a high pressure pump to produce the high pressure water flow needed in the system in the case of a fire accident.

The pressure produced by the pump is 70 bar or 90 bar respectively, according to the application. In stand-by position, the system pressure is maintained at 2 - 10 bar by means of the external water line pressure.

The MLPU1 can be started automatically or manually. Automatic start is activated by a Fire Detection System (FDS). Manual start can be launched either remotely from the external release panel or locally from the Starter Cabinet. External release and indication panel is normally included in the Marioff supply.

The Starter Cabinet is installed separately.





# Machinery Local protection Pump Unit MLPU 1

Starter Cabinet for product E01210.3

15 Jan 2009

1. HI-FOG manual start switch (delayed start 10 s)
2. Motor ampere meter
3. Control system on lamp
4. Pump unit fault lamp
5. 230 VAC earth fault lamp
6. Lamp test push button
7. Reset push button
8. Main power switch

Starter Cabinet size: 760 x 760 x 210 mm

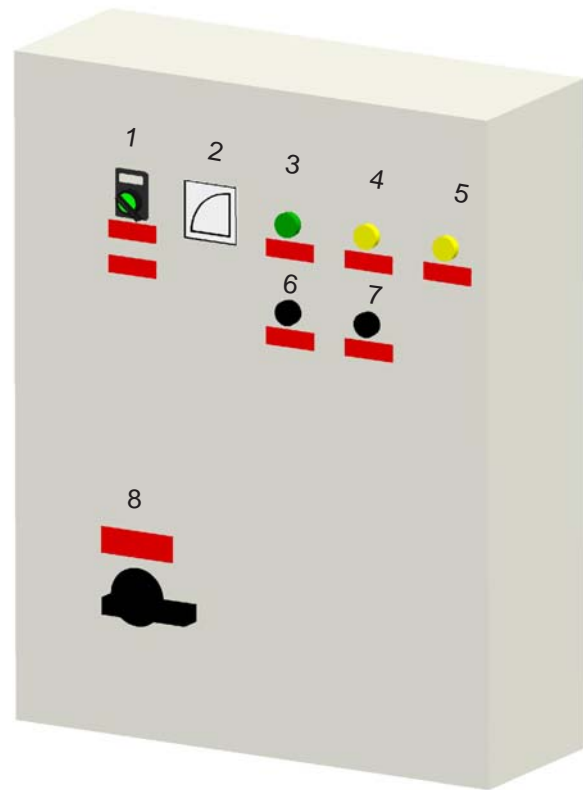

The Starter Cabinet is typically installed separately, near the MLPU unit. Starter Cabinet cabling is not included in the Marioff supply.

The electric power to the Starter Cabinet is normally supplied from the Main Switchboard (MSB). In case of a power failure, the supply from the Emergency Switchboard (ESB) is automatically switched on. Cable openings are at the bottom of the Starter Cabinet. The enclosure class is IP54.

The following signals will usually be led to the ship's automation system: pump unit running, pump unit fault. In addition, the start request to the external feed water pump is given if the starter of the feed water pump is not in the Starter Cabinet.

When ordering the MLPU1, the Starter Cabinet must be defined separately (see options in tables below). Other hardware options and possible FDS connections must also be defined when ordering the unit.

<b>Options for</b>	<b>MLPU 1 70/xx, MLPU 1 90/xx</b>
Feed water pump starter in the Starter Cabinet.	

<b>Voltage and Frequency options (to be defined when ordering)</b>	
<b>70 bar unit: 50 Hz - 23 kW or 60 Hz - 28 kW</b>	
<b>90 bar unit: 50 Hz - 30 kW or 60 Hz - 35 kW</b>	
690 VAC 50 Hz	690 VAC 60 Hz
400 VAC 50 Hz	440 VAC 60 Hz
380 VAC 50 Hz	



6 5 4 3 2 1

D  
C  
B  
A

Fresh Water Inlet BSP R1 1/2" female  
Water Inlet from Hydrophore  
BSP R1/2" Female

Filter Replacement

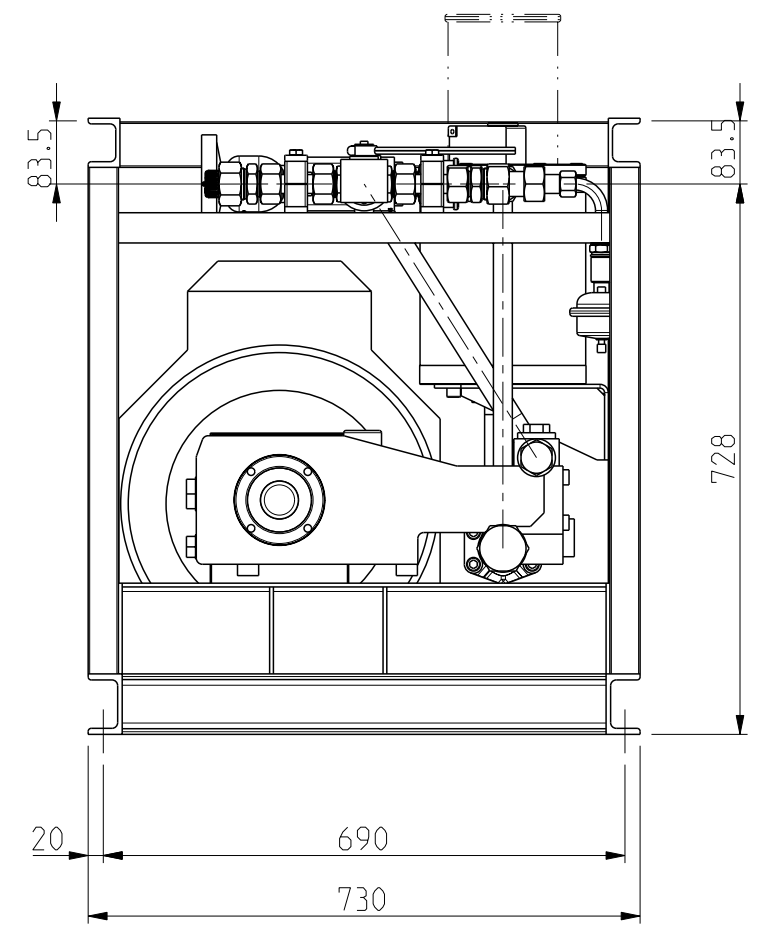
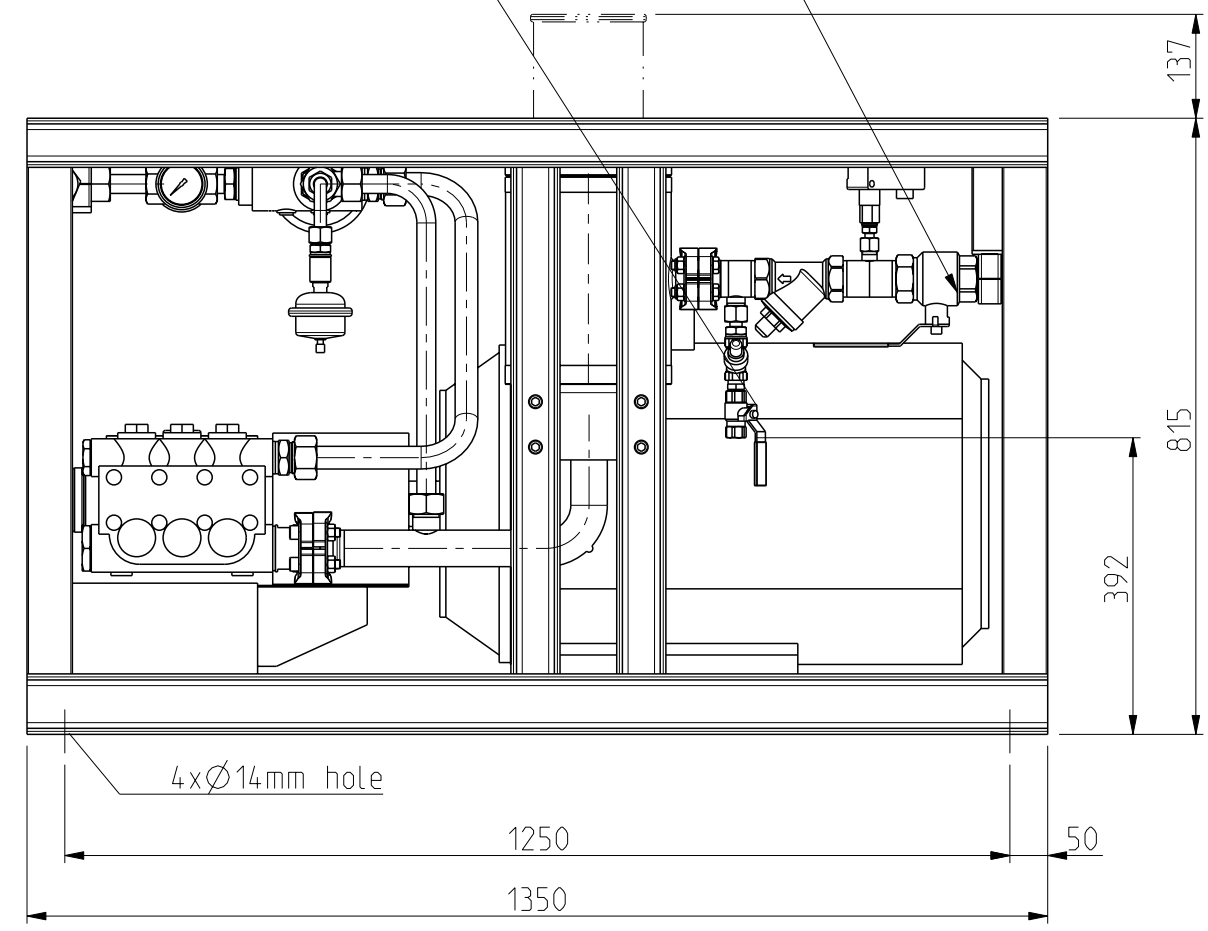
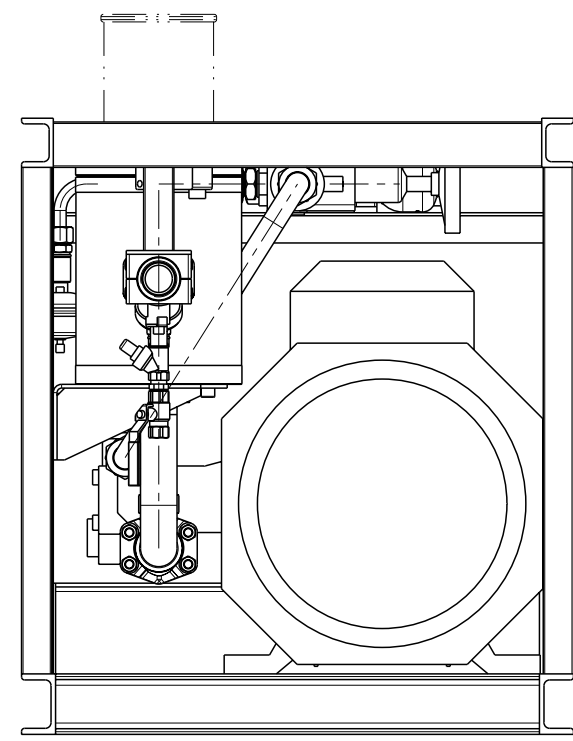

High Pressure Outlet Ø30x2.5

Test Line Outlet Ø30x2.5

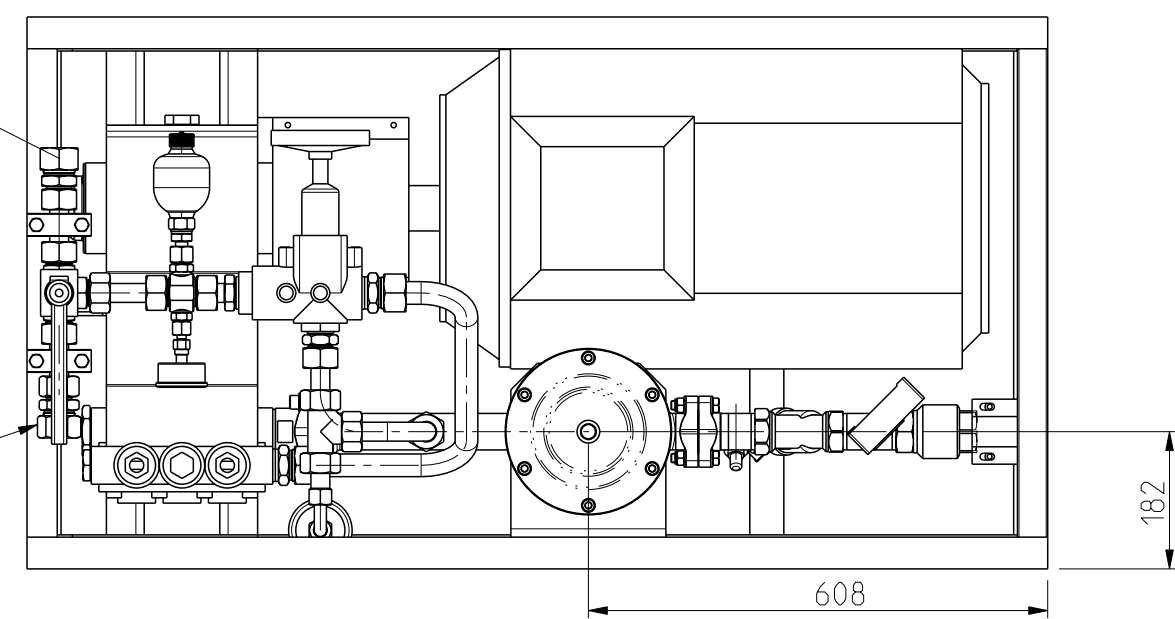

2316 So. 24<sup>th</sup> Street  
Omaha, NE 68108  
800.550.1AFP (1237) toll free  
402.733.2800 voice  
402.344.7469 fax  
www.associatedfire.net  
E-mail: info@associatedfire.net

**Marioff**

Scale: 1:10  
Units: mm  
Model: MLPUI

Drw. no.: DOC0001415 C  
Piir. no.: E01210.3

Product Tuote: E01210.3  
Material Materiaali:  
General Tolerance:  
Replaces:

Name Nimitys	PUMP UNIT MLPUI PUMP UNIT	Mass Massa	kg
Made Tekijä		21.09.06/PH	
Chkd Tark.			
Appd Hyv.			
Release level		WIP	
Sheet Sivu		1/2	

Rev.		Reason of Reviewing		Date	Reviewed	CN Ref.No
C	Paineakku (35 bar) vaihdettu			04.03.08	PH	0001114
B	Runko, piir nro matrix:sta			30.08.07	PH	0000780

This drawing is a property of Marioff Corp. It is not to be disclosed, traced, copied or published without our written consent. Not to be misused in any way

