



Machinery Space Accumulator Unit MAU 150 WM/FS

Stock codes E210XX (X: see table below)

TA

27 Apr 2005

Type	Model	150 bar	200 bar	250 bar
Wall Mounting models	MAU 150 WM	E21041	E21040	E21039
Floor Standing models	MAU 150 FS	E21052	E21051	E21050

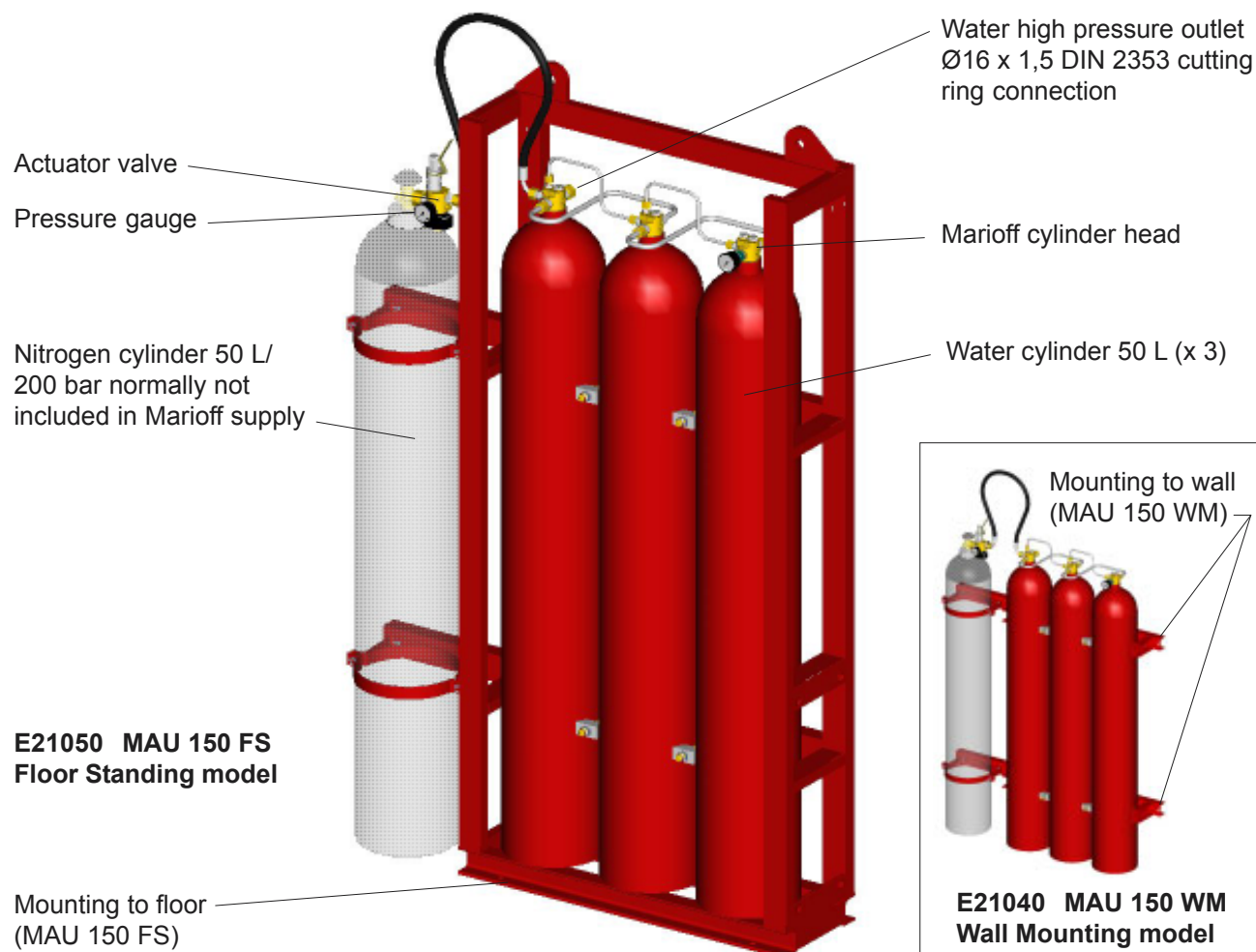

Model	Length [mm]	Width [mm]	Height [mm]	Mass* (dry) [kg]	Mass* (wet) [kg]	Max. output
MAU 150 WM	1230	284	1983	290	440	150 L
MAU 150 FS	1213	282	2015	300	450	150 L

*) given mass without a gas cylinder. As an example, a full 200 bar 50 litre N₂-cylinder mass is 62 kg.

Description

MAU (Machinery space Accumulator Unit) consists of water cylinders fully interconnected and powered by a pressurized nitrogen cylinder. The nitrogen cylinder is not supplied as local cylinders are recommended because of the national regulations. In stand-by situation, the water cylinders and the piping system are not pressurized. Upon actuation the unit will discharge on a continuous basis for the duration of discharge through the stainless steel piping and the HI-FOG spray heads.

The system activation can be done remotely or manually depending on the actuator valve. Once released, the nitrogen forces the water from cylinders to piping system and to spray heads. The discharge is normally designed for a 10 minute period.

For further information, see related documents: Dimensional Drawing no. DHAUMA000024A (MAU 150 WM)
Dimensional Drawing no. DHAUMA000025A (MAU 150 FS)



Machinery Space Accumulator Unit MAU 150 WM

Stock codes E21039, E21040 and E21041

TA

27 Apr 2005

Front view

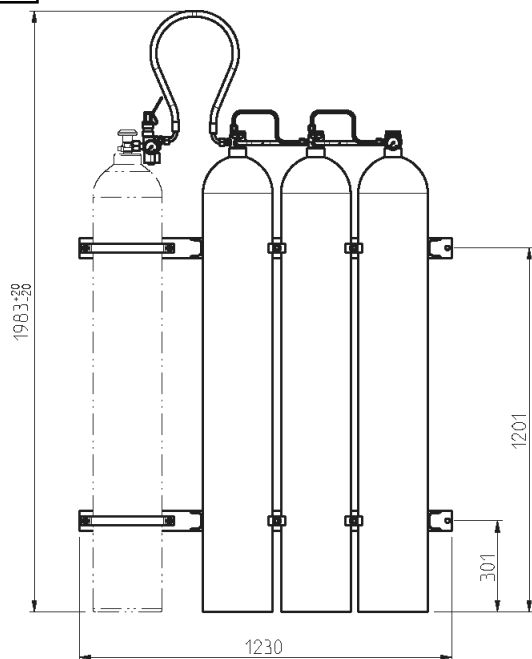

Side view

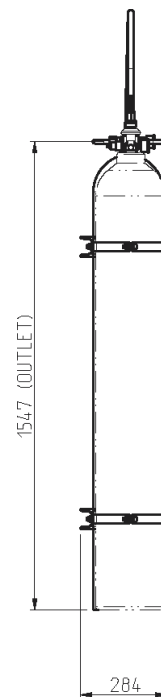

Top view

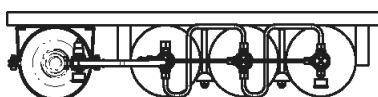

Mounting

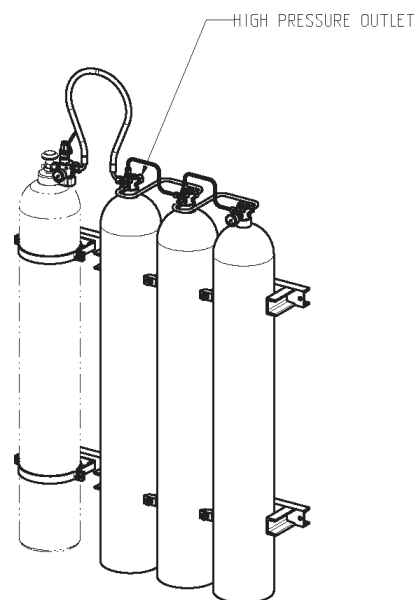
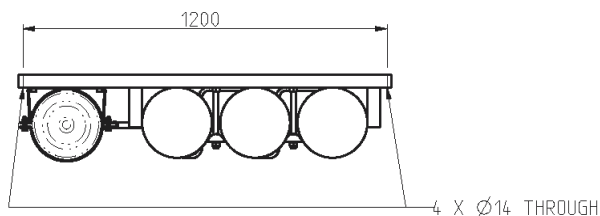

EXTERNAL PIPING CONNECTIONS	
CONNECTION	TYPE / DIMENSION
HIGH PRESSURE OUTLET	Ø16X1.5 DIN2353 CUTTING-RING FITTING





HI-FOG®

Machinery Space Accumulator Unit MAU 150 FS

Stock codes E21050, E21051 and E21052

TA

27 Apr 2005

Front view

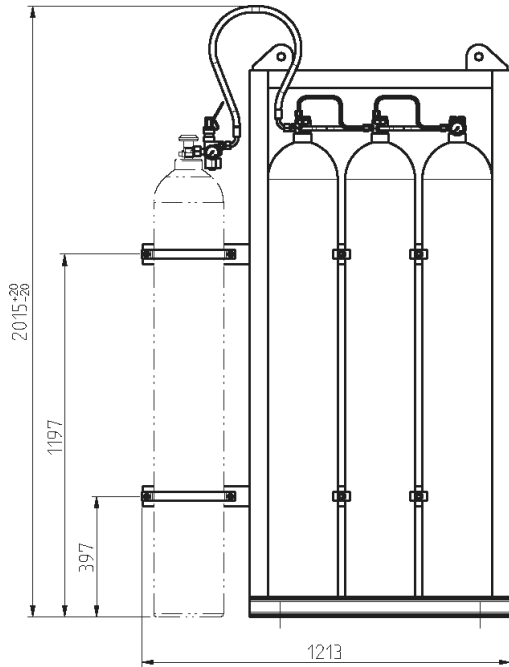

Side view

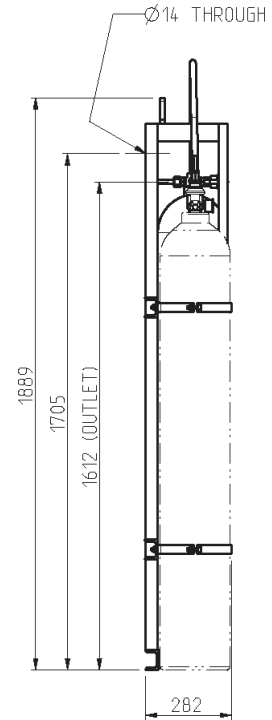

Top view

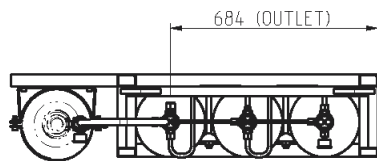

Mounting

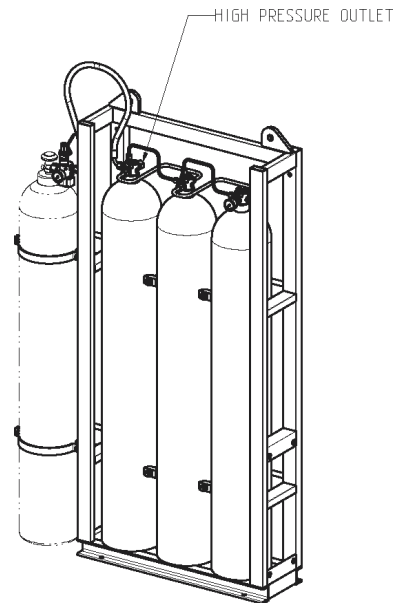
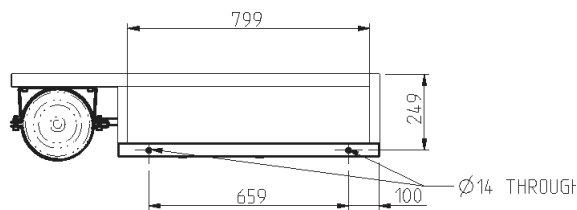

2316 So. 24th Street
 Omaha, NE 68108
 800.550.1AFP (1237) toll free
 402.733.2800 voice
 402.344.7469 fax
 www.associatedfire.net
 E-mail: info@associatedfire.net



EXTERNAL PIPING CONNECTIONS	
CONNECTION	TYPE / DIMENSION
HIGH PRESSURE OUTLET	Ø16X1.5 DIN2353 CUTTING-RING FITTING