

5 JOULE XENON & HIGH INTENSITY LED BEACONS EExd, Weatherproof SM87 & LED Ranges



Now VNIPO
Approved

Introduction

These certified beacons have been designed for use in harsh environmental conditions. The stainless steel or marine grade alloy enclosures are suitable for use offshore or onshore, where light weight combined with corrosion resistance and strength is required. Units can be painted to customer specification and fitted with identification labels.

LED version available, offering extended lifetimes.

A high temperature version is available – contact MEDC for details.



2316 So. 24th Street
Omaha, NE 68108
800.550.1AFP (1237) toll free
402.733.2800 voice
402.344.7469 fax
www.associatedfire.net
E-mail: info@associatedfire.net

- ★ Zone 1 and Zone 2 use.
 - ★ EExd IICT4/T6.
 - ★ ATEX approved Ex II 2GD.
 - ★ BASEEFA Certified.
 - ★ UL Listed for USA and Canada:
 - Class I, Div. 1, Groups C & D.
 - Class I, Zone 1 AExd IIB.
 - ★ CSA Certified.
 - ★ GOST 'R' & 'K' Certified*.
 - ★ Chinese (CQST) Certified.
 - ★ Brazilian (Inmetro) Certified.
 - ★ IP66 and IP67.
 - ★ Certified temperature* –55°C to +70°C.
 - ★ High temperature version (up to 85°C) available.
 - ★ Stainless steel or marine grade alloy.
 - ★ Xenon or LED versions.
 - ★ Various lens colours.
 - ★ Optional lens guard.
 - ★ Telephone or relay initiated.
- *Depending on version.

Sales Enq. Fax: +44 (0)1773 582830 Sales Orders Fax: +44 (0)1773 582832
E-Mail: sales@medc.com Web: www.medc.com



Specification

Certification: ATEX EExdIIC T6.

Cert. No. Baseefa 03ATEX0222.

CENELEC EN50014 and EN50018 and EN50019.

CSA Certification to C22.2 Nos. 0, 0.4, 0.5, 9, 30-M1986, 94-M91, 137-M1981. Class I. Div 1. Group D. Enclosure 3/4. Cert. No. 96406. (HXB only).

UL Listed for USA & Canada: Class I, Div 1, Groups C & D and Class 1, Zone 1. (HXB & XBT only). Listing No. E187894.

Refer to UL data sheet, at rear of catalogue, for complete information.

GOST 'R' Certification: 1Exd IIC T4, (HXB only) Russian Fire Approved (VNIPO).

GOST 'K' Certification: Exd IIC T4.

Chinese (CQST) Certification: Exd IIC T4/T6, (HXB only).

Brazilian (Inmetro) Certification: BR-Ex d IIC T3/T4/T5/T6

Material: HXBS, XBTS and LEDS – Grade 316 ANC4B Stainless Steel.

HXBA, XBTA & LEDA – LM25 TF Marine Grade Alloy.

Lens – Glass.

Note: Terminal Chamber available only in Stainless Steel.

UL version available only in marine grade alloy.

CSA version available only in stainless steel.

Finish: Epoxy paint finish as standard or to customer's specification.

Voltage	DC		AC 50/60 Hz				
	24	48	110	120	220	240	254
SM87 HXB XBT							
Tube Energy (Joules)	5	5	6	7	6	7	8
Peak Current							
Consumption (mA)	320	170	250	275	120	135	150
Effective Intensity (Cd)	29	29	32	39	32	39	44
Peak Intensity	22213	22213	25061	30187	25061	30187	34174
Power Consumption (Watts)	7.2	7.6	25	27	25	27	35
SM87 LED							
Current Consumption	165mA	85mA	N/A	N/A	N/A	N/A	N/A

FOR COLOURED LENSES

Colour	Red	Blue	Amber	Green	Yellow
Multiplying Factor	0.15	0.12	0.51	0.49	0.86

The photometric data has been verified by BSI. A report is available if required.

LED Light Output	Colour	Total LED Output (Candela)
Steady or Flashing (customer selectable)	Red	192
	Amber	64
	Green	17
	Blue	64

LED/Lens Colour: Red, Blue, Green, Amber, Yellow (not LED) or Clear (not LED).

Flash Rate: 60fpm as standard, other flash rates available on request.

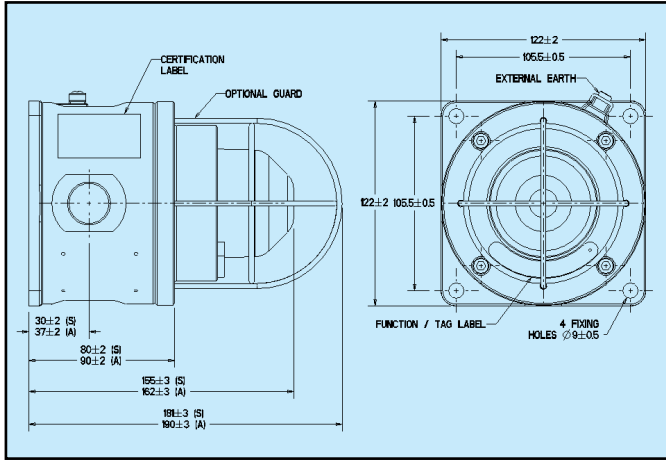

Weight: HXBS & LEDS – 3.8kg each (approx).
HXBA & LEDA – 2kg. each (approx.).

BASEEFA HXB = -55°C to +70°C.

Certified LED = -20°C to +40°C.

Temperature: Versions are available certified up to +55°C maximum with a T4 rating.
XBT (High temp) = -40°C to +85°C.

CSA Certified

Temperature: -50°C to +40°C.

UL Certified

Temperature: HXB = -55°C to +70°C. XBT (High Temp.) = -40°C to +85°C.

GOST 'R' Certified

Temperature: HXB = -55°C to +55°C.

Ingress

Protection: IP66 & IP67.

Terminals: HXB & XBT – 6 off suitable for up to 2.5mm² cable.

LED – 6 off suitable for up to 2.5mm² cable.

Telephone initiation or relay interface:

Initiation by telephone ringing tone or low voltage control signals.

Labels: Duty & Tag Labels optional.

Entries: Up to 4 x 20mm/25mm ISO or 1/2"/3/4" NPT.

Ordering Requirements

The following code is designed to help in the selection of the correct unit. Build up the reference number by inserting the code for each component into the appropriate box. **For standard products, available ex-stock, contact sales office for details.**

Model	Certification	Voltage	Lens/LEDcolour	Lens Guard	Entries	Tag/Duty Label	Initiate Option	Finish
<input type="text"/>	<input type="text"/>	<input type="text"/>	<input type="text"/>	<input type="text"/>	<input type="text"/>	<input type="text"/>	<input type="text"/>	<input type="text"/>
Type	Code	Certification Code	Colour Code	Voltage Code	Entries Code	Initiate Option Code	Finish Code	
Xenon (stainless steel)	SM87HXBS	ATEX B UL UL	Red R Blue B Green G Amber A Yellow Y (not LED) Clear C (not LED)	24V d.c. 024 48V d.c. not XBT 048 110V a.c. not LED, XBT110 120V a.c. 120 220V a.c. 220 240V a.c. 240 254V a.c. 254	20mm 1 25mm 2 1/2" NPT 3 3/4" NPT 4 Top *T Bottom *B RHS *R LHS *L	Telephone *T Relay *R EOL Resistor *E None N *Not available on UL versions.	Red R Blue B Yellow Y Yellow/Black Stripe X Grey G White W Special Finish S	
Xenon (alloy)	SM87HXBA	CSA C						
Xenon High Temp. (alloy)	SM87XBTA*	GOST 'R' G GOST 'K' K Chinese (CQST) Q						
Xenon High Temp. (stainless steel)	SM87XBTS*	Inmetro DM						
LED EExd (stainless steel)	SM87LEDS	Only HXBS is available CSA certified. Only HXBA & XBTA is available UL certified.						
LED EExd (alloy)	SM87LEDA							
*XBT only available 24V d.c.								
*VNIPO Approved as standard.								
*prefix position with entry size code. e.g. 1R1B=20mm Right and Bottom entries.								
Guard	Code	Label	Code					
None	N	None	N					
Yes	Y	Yes	Y	(Please specify)				



All the above specifications, dimensions, weights and tolerances are nominal (typical) and MEDC reserve the right to vary all data without prior notice. No liability is accepted for any consequence of use.